

Application of Glycals to the Synthesis of Oligosaccharides: Convergent Total Syntheses of the Lewis X Trisaccharide Sialyl Lewis X Antigenic Determinant and Higher Congeners

Samuel J. Danishefsky,^{*,†} Jacquelyn Gervay, John M. Peterson, Frank E. McDonald, Koshi Koseki, David A. Griffith, Takeshi Oriyama, and Stephen P. Marsden

Contribution from the Department of Chemistry, Yale University, New Haven, Connecticut 06511, Laboratory for Bioorganic Chemistry, Sloan-Kettering Institute for Cancer Research, Memorial Sloan-Kettering Cancer Center, New York, New York 10021, and the Department of Chemistry, Columbia University, New York, New York 10027

Received May 25, 1994[®]

Abstract: Exploiting the differences in reactivity of the hydroxyl groups of glucal allows for rapid access to the sLe^x tetrasaccharide glycal. This compound is readily converted to the title compounds by azaglycosylation followed by deprotection. The use of stannyl alkoxides in the glycosylation–rearrangement step allows for the use of minimally protected glycosides as the glycosyl acceptors. Employing a galactal epoxide as a glycosyl donor allows for a maximally convergent synthesis of the Le^x glycal.

Introduction

The selectins are a family of cell adhesion molecules involved in various aspects of immune cell trafficking. They are structurally related in that they contain an extracellular amino terminal lectin domain, an EGF-receptor-like domain, and various numbers of repeating complement domains.¹ Three members of the family are known. L-selectin (formerly called leukocyte endothelial cell adhesion molecule or LECAM-1) mediates migration of leukocytes from the bloodstream into the lymphatic system.² E-selectin (formerly called endothelial leukocyte adhesion molecule or ELAM-1) is synthesized and expressed on the luminal surface of endothelial cells in areas of tissue injury upon activation by various cytokines.³ The presence of E-selectin causes circulating neutrophils and monocytes to bind to and slowly roll along the blood vessel wall. This rolling eventually stops and the lymphocytes migrate into the damaged tissue. The rolling activity is controlled by other proteins. P-selectin (formerly called granule membrane protein-140 or GMP-140) is found in secretory granules of the endothelium. Upon activation by thrombin, histamine, or peroxide, these granules move to the cell surface where the P-selectin thus presented induces lymphocyte rolling in a manner similar to that of E-selectin.⁴

The presence of the lectin domains of these glycoproteins prompted a search for carbohydrate ligands. In 1990, it was

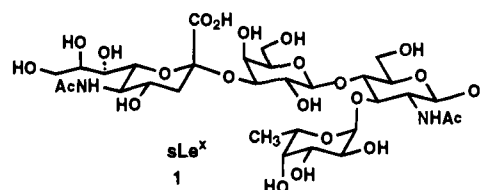

Figure 1.

discovered that E-selectin recognizes the tetrasaccharide sialyl Lewis X antigenic determinant (sLe^x, 1, Figure 1).⁵ sLe^x is found at the nonreducing termini of several glycoproteins and glycolipids found on the surface of neutrophils. P-selectin was also found to induce adhesion of sLe^x carrying lymphocytes.⁶ These disclosures, in addition to offering new insights into immune system function, suggested the possibility of new approaches for the treatment of immune disorders via inhibition of cell adhesion.⁷

sLe^x is also a tumor associated antigen.⁸ It is present to an abnormal extent in cancerous stomach, colon, lung, esophageal, ovarian, pancreatic, and breast cells. Tumor cells expressing sLe^x bind to areas of the vascular endothelium expressing E-selectin.⁹ This suggests a mechanism for tumor metastasis as well as new therapeutic approaches.

The exciting biological implications of the sLe^x/E-selectin interactions coupled with the low availability of sLe^x from

[†] Present addresses: Kettering Chair and Director of the Laboratory for Bioorganic Chemistry, The Sloan-Kettering Institute for Cancer Research, 1275 York Avenue, Box 106, New York, NY 10021, and Professor of Chemistry, Columbia University, Havemeyer Hall, New York, NY 10027.

[®] Abstract published in *Advance ACS Abstracts*, February 1, 1995.

(1) Stoolman, L. M. *Cell* **1989**, *56*, 907.

(2) Gallatin, M.; Weissman, I.; Butcher, E. *Nature* **1983**, *303*, 30.

(3) (a) Bevilacqua, M. P.; Pober, J. S.; Mendrick, D. L.; Cotran, R. S.; Gimbrone, M. A. *Proc. Natl. Acad. Sci. U.S.A.* **1987**, *84*, 9238. (b) Kuijpers, T. W.; Hakkert, B. C.; Hoogerwerf, M.; Leuvenberg, J. F. M.; Roos, D. *J. Immunol.* **1991**, *147*, 1369. (c) Lusinskas, F. W.; Brock, A. F.; Arnaout, M. A.; Gimbrone, M. A. *J. Immunol.* **1989**, *142*, 2257.

(4) (a) Butcher, E. C. *Cell* **1991**, *67*, 1033. (b) Lawrence, M. B.; Springer, T. A. *Cell* **1991**, *65*, 859. (c) Ley, K.; Gaetgens, P.; Fennie, C.; Singer, M.; Lasky, L. A.; Rosen, S. *Blood* **1991**, *77*, 2553. (d) Shimizu, Y.; Shaw, S.; Graber, N.; Gopal, T. V.; Horgan, K. J.; Van Seventer, G. A.; Newman, W. *Nature* **1991**, *349*, 799.

(5) (a) Phillips, M. L.; Nudelman, E.; Gaeta, F. C. A.; Perez, M.; Singhal, A. K.; Hakamori, S.; Paulson, J. C. *Science* **1990**, *250*, 1130. (b) Walz, G.; Aruffo, A.; Kolanus, W.; Bevilacqua, M.; Seed, B. *Science* **1990**, *250*, 1132. (c) Lowe, J. B.; Stoolman, L. M.; Nair, R. P.; Larsen, R. D.; Berhend, T. L.; Marks, R. M. *Cell* **1990**, *63*, 475. (d) Tiemyer, M.; Swiedler, S. J.; Ishihara, M.; Moreland, M.; Schweingruber, H.; Hirtzer, P.; Brandley, B. K. *Proc. Natl. Acad. Sci. U.S.A.* **1991**, *88*, 1138.

(6) Polley, M. J.; Phillips, M. L.; Wayner, E.; Nudelman, E.; Singhal, A. K.; Hakamori, S.; Paulson, J. C. *Proc. Natl. Acad. Sci. U.S.A.* **1991**, *88*, 6224.

(7) (a) *Chem. Eng. News* **1993**, *71* (June 28). (b) *Chem. Eng. News* **1992**, *70* (Dec 7).

(8) (a) Fukushima, O.; Hirota, M.; Terasaki, P. I.; Wakisaka, A.; Togashi, H.; Chia, D.; Naofumi, S.; Fukushi, Y.; Nudelman, E.; Hakamori, S. *Cancer Res.* **1984**, *44*, 5279. (b) Hanisch, F.-G.; Hanski, C.; Hasegawa, A. *Cancer Res.* **1992**, *52*, 3138.

(9) Takada, A.; Ohmori, K.; Yoneda, T.; Tsuyuoka, K.; Hasegawa, A.; Kiso, M.; Kannagi, R. *Cancer Res.* **1993**, *53*, 354.

natural sources has made it an attractive synthetic target. Several syntheses have been reported to date¹⁰ including one communication from our group.^{10,11} A detailed account of the underlying reasoning and reduction to practice of this highly convergent synthesis are described herein.

Strategy and Results

A key interim target chosen for our sLe^x synthesis was the tetrasaccharide glycal **2**. The identification of this compound as a goal structure was in keeping with the interest of our laboratory in glycals.¹² It subsequently transpired that glycal **2** itself effectively blocks sLe^x mediated leucocyte adhesion to E-selectin. This finding strongly suggests the nonrelevance of the *N*-acetyl function to the binding requirements.¹³

It was envisioned that the double bond would serve as a handle for the introduction of the glucosamine C-2 *N*-acetate and various entities at the reducing terminus using the sulfonamidoglycosylation method previously developed in our laboratory.¹⁴ The other disconnections and the order of glycosylations are shown in Scheme 1 (see arrows 1, 2, and 3).

A critical perception in our plan to promote maximal convergence was the possibility of achieving fucosylation of a monoprotected glucal at the less hindered and more reactive allylic C-3 hydroxyl. We envisioned using a fucosyl fluoride as the glycosyl donor to establish the Fuc α (1 \rightarrow 3) glucal linkage, since the relatively neutral conditions of such a glycosylation would be expected to be compatible with preservation of the sensitive glycal moiety. It was further proposed that a β -linked galactose could be installed at C-4 subsequent to the fucosylation.

The program started with the testing of these two suppositions. Treatment of D-glucal with *tert*-butyldiphenylsilyl chloride generated the monoprotected derivative **4** in 90% yield. Reaction of **4** with tri-*O*-benzylfucosyl fluoride (**5**) (as a 1:1 α : β anomeric mixture)^{10(d)} using AgClO₄/SnCl₂ as the promoter system in ether¹⁵ provided a complex mixture of products reflecting decomposition of the acid sensitive glucal. Repeating the reaction in the presence of 2,6-di-*tert*-butylpyridine (DTBP) allowed for the isolation of three disaccharides, **6**, **7**, and **8**, in 90% yield and in a 5:3:1 ratio (Scheme 2). Separation of the fucosyl fluoride anomers and repetition of this experiment using

Scheme 1

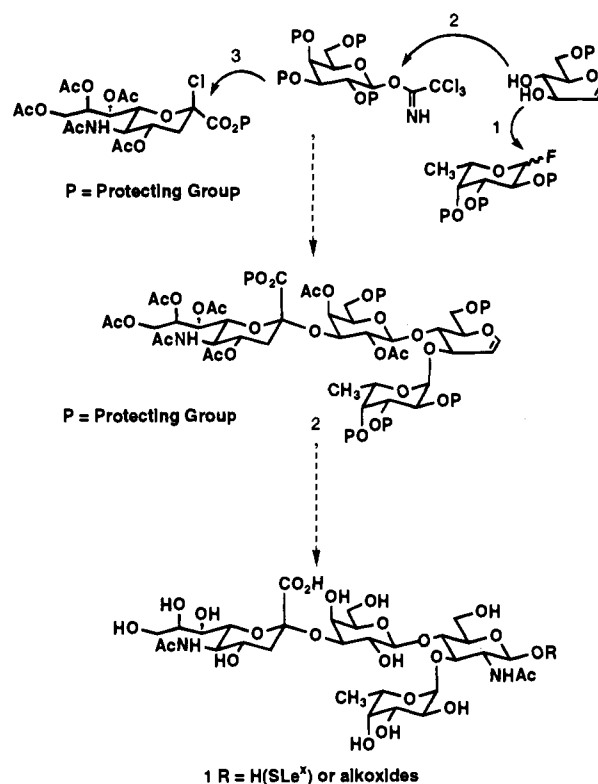

Scheme 2

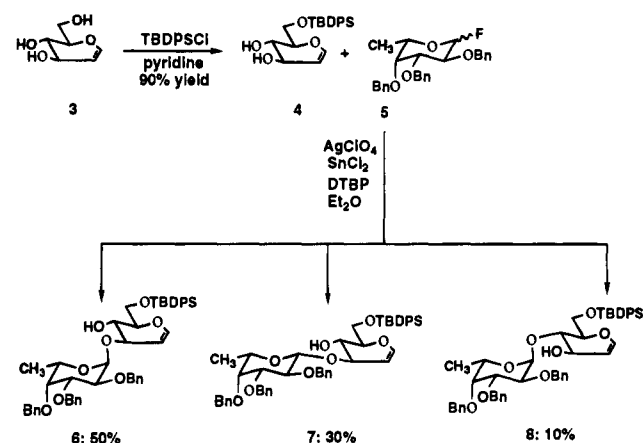

the individual isomers produced the same product ratio. The anomeric stereochemistry of **6** was assigned as α on the basis of the 3.9 Hz coupling constant of the fucose C-1 proton. The site of fucosylation in the major product (**6**) was determined by acetylation and observation of a downfield shift of the glucal C-4 proton. Similar analyses established the other monofucosylation products to be **7** and **8**.

While the 8:1 regiochemical outcome favoring glycosylation at C-3 was acceptable for the synthesis, the stereochemical result was surprising and disappointing in light of earlier findings in related systems.¹⁶ Apparently the C-3 hydroxyl of **4** lacks sufficient steric augmentation at the C-2 and C-4 positions to allow for powerful stereocontrol.¹⁷ We envisioned that placement of a benzoate group on the C-4 hydroxyl of the fucosyl fluoride would correct the problem.¹⁸ Stannyl alkoxide¹⁹

(10) (a) Palcic, M. M.; Venot, A. P.; Ratcliffe, R. M.; Hindsgaul, O. *Carbohydr. Res.* **1989**, *190*, 1. (b) Kameyama, A.; Ishida, H.; Kiso, M.; Hasegawa, A. *Carbohydr. Res.* **1991**, *209*, C1. (c) Kameyama, A.; Ishida, H.; Kiso, M.; Hasegawa, A. *J. Carbohydr. Chem.* **1991**, *10*, 549. (d) Nicolaou, K. C.; Hummel, C. W.; Bockovich, N. J.; Wong, C.-H. *J. Chem. Soc., Chem. Commun.* **1991**, *10*, 870. (e) Dumas, D. P.; Ichikawa, Y.; Wong, C.-H.; Lowe, J. B.; Rajan, P. N. *Bioorg. Med. Chem. Lett.* **1991**, *1*, 425. (f) Nicolaou, K. C.; Hummel, C. W.; Iwabuchi, Y. *J. Am. Chem. Soc.* **1992**, *114*, 3126. (g) Ball, G. E.; O'Neill, R. A.; Schultz, J. E.; Lowe, J. B.; Weston, B. W.; Nagy, J. O.; Brown, E. G.; Hobbs, C. J.; Bednarski, M. D. *J. Am. Chem. Soc.* **1992**, *114*, 5449. (h) Ichikawa, Y.; Lin, Y.-C.; Dumas, D. P.; Shen, G.-J.; Garcia-Juncenda, E.; Williams, M. A.; Bayer, R.; Ketcham, C.; Walker, L. E.; Paulson, J. C.; Wong, C.-H. *J. Am. Chem. Soc.* **1992**, *114*, 9283.

(11) For a preliminary account of this work, see: (a) Danishefsky, S. J.; Gervay, J.; Peterson, J. M.; McDonald, F. E.; Koseki, K.; Oriyama, T.; Griffith, D. A.; Wong, C.-H.; Dumas, D. P.; *J. Am. Chem. Soc.* **1992**, *114*, 8329. (b) Danishefsky, S. J.; Koseki, K.; Griffith, D. A.; Gervay, J.; Peterson, J. M.; McDonald, F. E.; Oriyama, T. *J. Am. Chem. Soc.* **1992**, *114*, 8331.

(12) (a) Friesen, R. W.; Danishefsky, S. J. *J. Am. Chem. Soc.* **1989**, *111*, 6656. (b) Halcomb, R. L.; Danishefsky, S. J. *J. Am. Chem. Soc.* **1989**, *111*, 6661. (c) Chow, K.; Danishefsky, S. J. *J. Org. Chem.* **1990**, *55*, 4211. (d) Gervay, J.; Danishefsky, S. J. *J. Org. Chem.* **1991**, *56*, 5448.

(13) DeFrees, S. A.; Gaeta, F. C. A.; Lin, Y.-C.; Ichikawa, Y.; Wong, C. H. *J. Am. Chem. Soc.* **1993**, *115*, 7549.

(14) (a) Griffith, D. A.; Danishefsky, S. J. *J. Am. Chem. Soc.* **1990**, *112*, 5811. (b) Griffith, D. A.; Danishefsky, S. J. *J. Am. Chem. Soc.* **1991**, *113*, 5863.

(15) Mukaiyama, T.; Murai, Y.; Shoda, S. *Chem. Lett.* **1981**, 431.

(16) For an example of a stereoselective reaction of **5** at the allylic position of a glycal, see: Berkowitz, D. B.; Danishefsky, S. J.; Schulte, G. K. *J. Am. Chem. Soc.* **1992**, *114*, 4518.

(17) For an example of protecting groups on the glycosyl acceptor influencing the outcome of a glycosylation, see: Spijker, N. M.; van Boeckel, C. A. A. *Angew. Chem., Int. Ed. Engl.* **1991**, *30*, 180.

Scheme 3

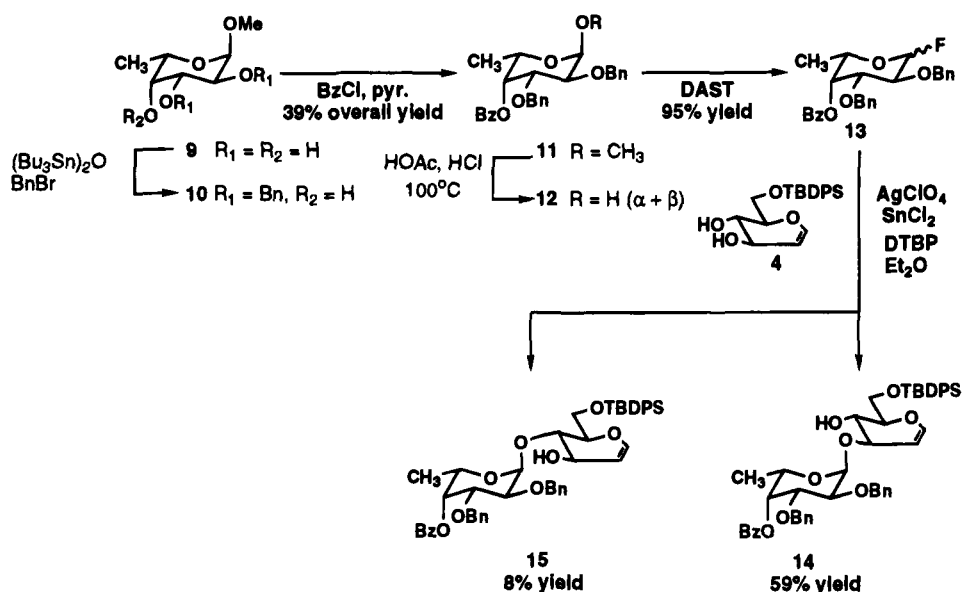

Scheme 4

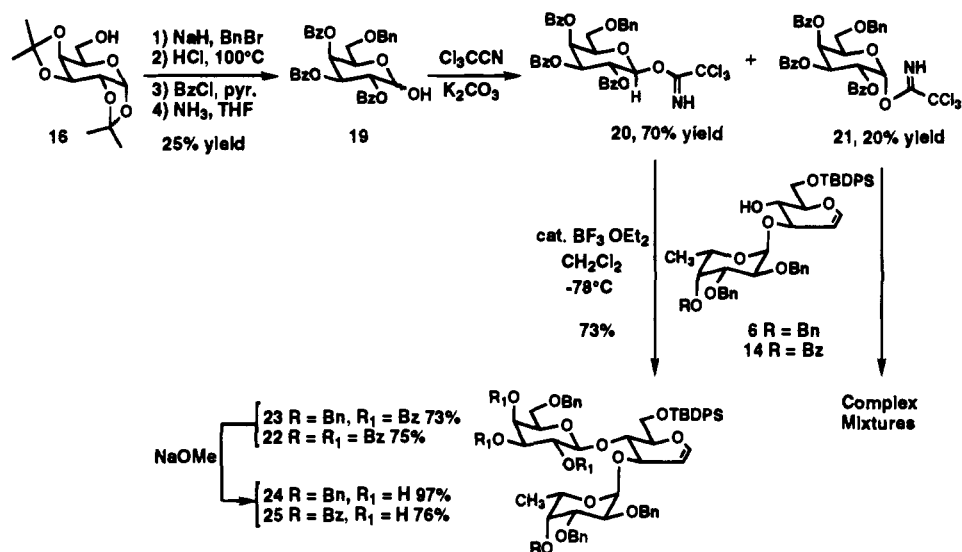

mediated dibenylation of L-fucose α -methyl glycoside generated the known 2,3-dibenzylated compound **10**.¹⁸ Benzylation then afforded **11** (Scheme 3). Hydrolysis of the methyl glycoside to give **12** followed by treatment with DAST in THF generated the desired fluoride **13** as a 1:6 α : β anomeric mixture.

Reaction of **4** and **13** using conditions similar to those as above generated two disaccharides, **14** and **15** in 59% and 8% yields, respectively (Scheme 3). Structure determination as described earlier showed **14** to be the desired (1 \rightarrow 3) α product and **15** to be the (1 \rightarrow 4) α product. Gratifyingly, no β -linked disaccharides were detected. Thus, regioselective fucosylation of a glucal provided a substrate with a uniquely free C-4 hydroxyl ready to function as a galactosyl acceptor.

We next considered a reasonable galactosyl donor candidate. After some trial and error we selected 2,3,4-tri-*O*-benzoyl-6-*O*-benzyl- β -D-galactopyranosyl trichloroacetimidate (**20**). This compound was prepared from the commercially available diacetone galactose **16**. Benzylation²⁰ of **16** followed by acetonide hydrolysis²¹ provided the known 6-*O*-benzylgalactose

(**17**). Perbenzylation to provide **18** and selective removal of the anomeric benzoate then afforded **19** in 25% overall yield. Treatment of **19** with K_2CO_3 and Cl_3CCN ²² provided a 90% yield of **20** and its α anomer **21**, in a 7/2 ratio.

Reaction of **20** with **6** in CH_2Cl_2 with a catalytic amount of $\text{BF}_3\cdot\text{OEt}_2$ generated the β -linked trisaccharide **22** in 75% yield (Scheme 4). Surprisingly, use of the α imidate under identical reaction conditions led to a complex mixture of products from which **22** could be isolated in only 11% yield. Use of disaccharide **14** as the glycosyl acceptor in a reaction with **20** as above afforded 73% of the desired β -linked trisaccharide. Attempted coupling of the α anomer **21** with **14** again led to complex mixtures.

The trisaccharides **22** and **23** were readied for sialylation by methanolysis of the galactosyl benzoates to provide the trisaccharide triols **24** and **25** in 97% and 76% yields, respectively (Scheme 4). The fucosyl benzoate of **23** had survived the process. Longer reaction times were required to effect its removal.

Trisaccharides **24** and **25** were targeted to be the acceptors for conversion into the key intermediate tetrasaccharide glycals

(18) DeJter-Juszynski, M.; Flowers, H. M. *Carbohydr. Res.* **1973**, *28*, 61.

(19) David, S.; Hanessian, S. *Tetrahedron* **1985**, *41*, 643.

(20) Ballou, C. E.; Fischer, H. O. L. *J. Am. Chem. Soc.* **1954**, *76*, 3188.

(21) Anet, E. F. L. *J. Carbohydr. Res.* **1968**, *7*, 84.

(22) Schmidt, R. R.; Michel, J. *Tetrahedron Lett.* **1984**, 821.

Scheme 5

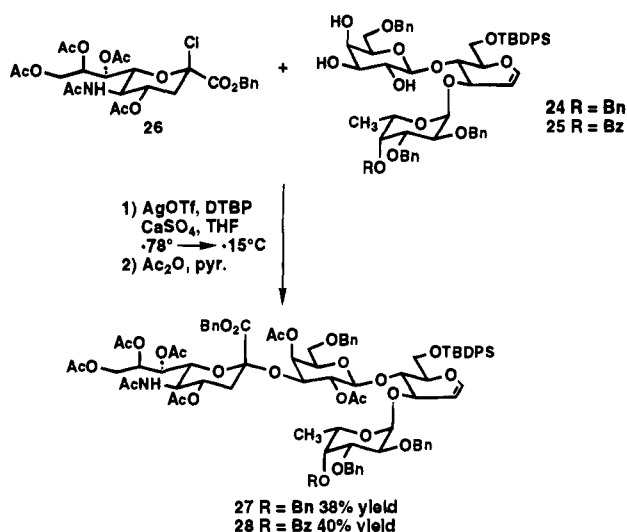

(see **27** and **28**) by reaction with the donor sialyl chloride **26**.²³ As with the glucal fucosylation reactions above, our choice of glycosyl donor was dictated by the presence of an electrophilic glycal residue in the acceptor trisaccharide. In the event, reaction of **26** with trisaccharide triol **24** in THF using AgOTf as the promoter and di-*tert*-butylpyridine as a proton scavenger followed by acetylation of the crude reaction mixture resulted in the isolation of the desired (2→3) α -linked sialoside **27** in 38% yield (75% yield based on recovered **24**). The stereochemistry of the new glycosidic linkage was determined to be α on the basis of the occurrence of the NeuAc H-4 at δ 4.8 ppm as well as the $J_{\text{NeuAc } 7-8}$ of 8.6 Hz. Similarly, reaction of **26** with **25** as above provided the (2→3) α -linked sialoside **28** in 40% isolated yield (78% based on recovered **25**). The stereochemistry of glycosylation was determined as above. Thus, our desired key intermediate, the sLe^x glycal, was in hand albeit in protected form.

The tetrasaccharides **27** and **28** were deprotected. Removal of the silyl group with TBAF was followed by ester hydrolysis. Cleavage of the benzyl ethers and peracetylation provided compound **29**, which was readily purified using column chromatography. Finally, hydrolysis of the acetates followed by cleavage of the methyl ester then provided the fully deprotected sLe^x glycal **30** (61% overall yield starting from **27** and 77% overall yield starting from **28**).

The next goal was the introduction of functionality across the glycal double bond, thereby leading to the sLe^x (with a free reducing end) and higher congeners thereof. Treatment of tetrasaccharide **27** with benzenesulfonamide or 2-(trimethylsilyl)ethanesulfonamide in the presence of iodonium bis(*sym*-collidine) perchlorate afforded the iodosulfonamides **31** and **32** in 91% and 82% yields, respectively (Scheme 7). The previously reported conditions for rearrangement of iodosulfonamides of this type to 2-amino sugars called for the use of lithium or potassium alkoxides.¹⁴ Not surprisingly, attempts to effect rearrangement under these conditions failed, due to serious complications arising from the presence of the various ester groups.

Fortunately, it was found that the required rearrangement could be carried out under mild conditions using stannyl alkoxides. Thus, treatment of **31** with tributyltin methoxide and AgOTf in THF at low temperature resulted in the formation of the β -linked methyl glycoside **33** in 70% yield. Similarly,

reaction of iodosulfonamide **32** with tributyltin benzyloxyde²⁴ led to generation of the β -linked benzyl glycoside **34** in 64% yield (Scheme 8). The deprotection sequence began with the action of CsF on **34**, resulting in cleavage of the silyl and SES groups. This was followed by peracetylation to furnish compound **35**. Acetate and ester hydrolysis followed by reductive cleavage of the benzyl ethers afforded fully synthetic sLe^x antigen in 22% overall yield as a 2:1 α : β mixture of anomers. The spectral data for this mixture (see Experimental Section) were consistent with the target molecule and closely matched those previously reported.^{10d}

The scope of the stannyl alkoxide mediated sulfonamidoglycosylation reaction was explored by application to two carbohydrate acceptors, **36** and **37**. The former was generated by treatment of the 6-*tert*-butyldiphenylsilyl derivative of galactal with bis(tributyltin) oxide in refluxing benzene under Dean-Stark conditions. Similarly bis-silylation of lactal using *tert*-butyldimethylsilyl chloride followed by stannylation as above generated the 6,6'-*O*-bis(silyl)-3'-*O*-stannyl derivative **37**.

Reaction of iodosulfonamide **31** with galactal derivative **36** in THF in the presence of AgBF₄ resulted in formation of the pentasaccharide glycal **38** in 52% isolated yield (Scheme 9). Similarly, reaction of **31** with lactal derivative **37** as above provided the hexasaccharide glycal **39** in 43% isolated yield (Scheme 10). Silyl removal with TBAF followed by ester hydrolysis, benzyl ether and sulfonamide cleavage, then peracetylation generated the hexasaccharide lactone **40** in 77% overall yield. Detailed NMR experiments on this compound firmly established the stereochemistry of each of the glycosidic linkages as those shown, further verifying our original assignments.

While the work presented above represents an extremely rapid and efficient approach to the sialyl Lewis X tetrasaccharide, we were interested to investigate whether further applications of glycal chemistry would allow us additional synthetic economies. In particular, we sought to bypass the need for recourse to galactosyl donor **20**, since several steps had been required for its preparation from commercially available starting materials. Specifically, we wondered whether an α -epoxide **42** derived from galactal **41** could serve as a useful galactosylating agent with respect to the C-4 hydroxy of a glucal **43** bearing a branching α -fucoside linkage at C-3. Since C-4 based acceptors tend to perform relatively poorly with glycal epoxides, we wished to employ a particularly efficacious version of such a donor. Experience in our laboratories in coupling hindered alcohols with epoxides derived from cyclic carbonate protected galactals such as **42** was particularly encouraging in context of the case at hand.

In order to test this proposition, **43** was prepared (*via* glucal **44**) in a manner analogous to that of disaccharide **14**, while **41** was prepared by the regioselective silylation of galactal **45**, followed by protection of the 3- and 4-hydroxyl groups of **46** as their cyclic carbonate (Scheme 11). Epoxidation of **41** with dimethyldioxirane afforded **42**. This product was subjected to the action of **43** in the presence of zinc bromide at low temperature to afford an excellent (81%) yield of trisaccharide glycal **47**, together with 17% of unreacted **43**. Exhaustive deprotection of **47** gave the free Le^x glycal **48** (29% yield), while selective removal of the cyclic carbonate with sodium methoxide furnished triol **49** (89% yield), which may be considered as the synthetic equivalent of sialyl acceptor **25**. This represents the most demanding application yet of a glycal-epoxide glycosy-

(23) Ratcliffe, M. R.; Venot, A. P.; Abbas, Z. S. Eur. Pat. Appl. EP 319,253, 1990 (*Chem. Abstr.* 1990, 112, 175281a).

(24) Davies, A. G.; Kleinschmidt, D. C.; Palan, P. R.; Vasishtha, S. C. *J. Chem. Soc. C* 1971, 3972.

Scheme 6

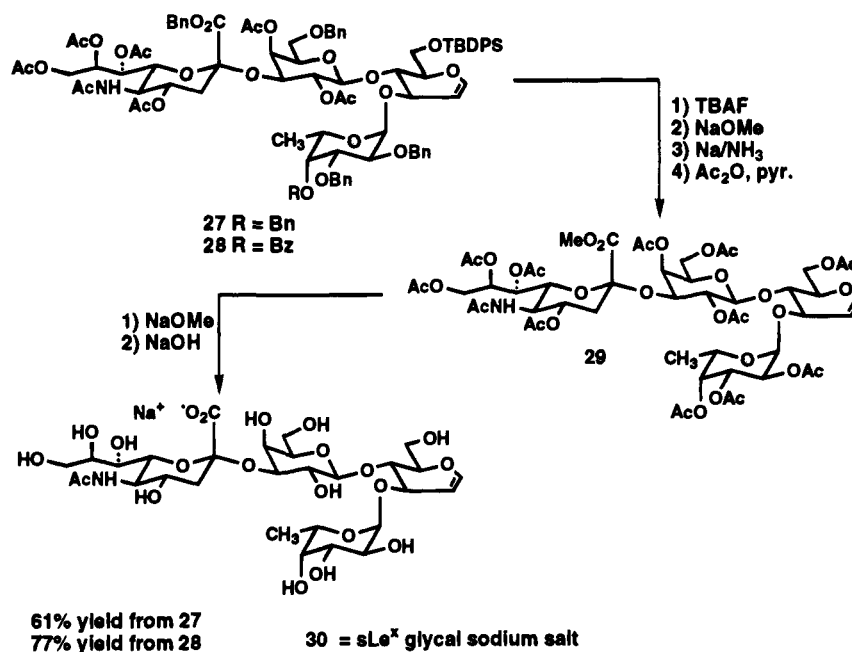

Scheme 7

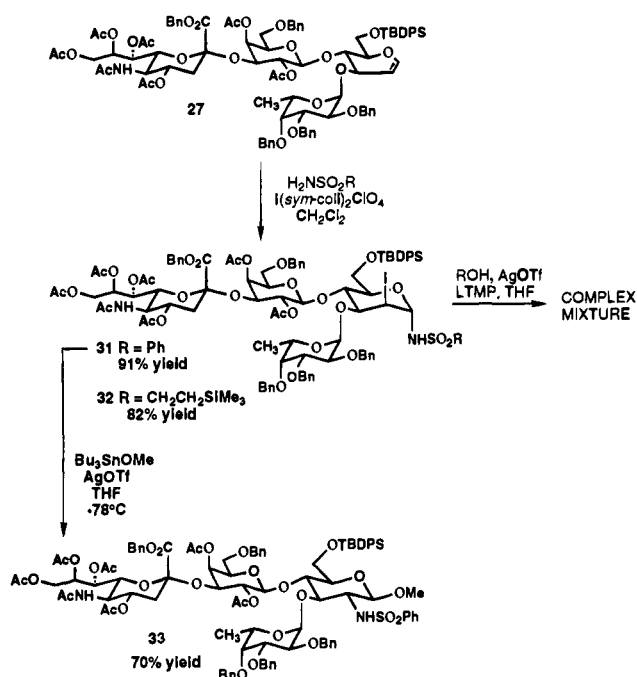

Scheme 8

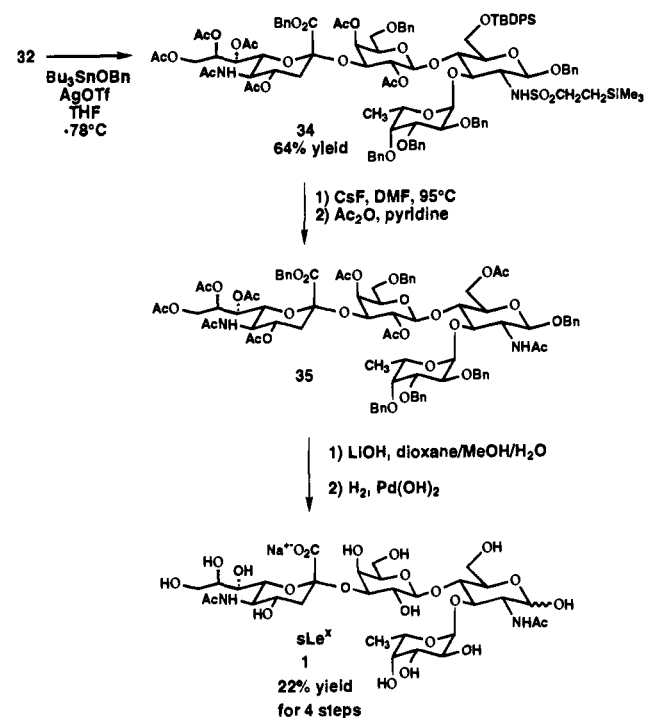

lation, and its success is apparent in a shortened, high-yielding approach to the target trisaccharide system **48**. The route shown here is clearly the most convergent access to the Le^x glycal series. Given the amenability of glycals to various functionalization protocols, such access to the Le^x blood group glycal might be particularly rewarding.

In summary, this work has resulted in remarkably convergent total syntheses of sialyl Lewis antigen X determinant and higher congeners using glycals as intermediates. Regio- and stereo-selective fucosylation of glucal followed by galactosylation and sialylation allowed for rapid access to the sLe^x glycal. Conversion of this glycal to an iodosulfonamide generated a viable glycosyl donor under very mild conditions. The use of stannyl alkoxides allowed for regiospecific introduction of minimally protected carbohydrate acceptors. A more concise route to the Le^x glycal has been demonstrated, employing a galactal derived epoxide to effect the galactosylation reaction. The glycal

method is certainly among the most convergent chemical routes to the sLe^x family of compounds.

Experimental Section

6-O-(*tert*-Butyldiphenylsilyl)-1,5-anhydro-2-deoxy-*arabino*-hex-1-enopyranose (4). D-Glucal (3.55 g, 24.3 mmol) was dissolved in 100 mL of dry pyridine and cooled to 0 °C. DMAP (50 mg) was added followed by *tert*-butyldiphenylsilyl chloride (7.6 mL, 29.2 mmol). The mixture was stirred for 8 h and allowed to warm to room temperature. The solvent was removed *in vacuo* and the residue subjected to flash chromatography, eluting with 40:60 EtOAc:hexanes to give 8.41 g of **4** as a thick, clear oil (90% yield): [α]_D²⁰ +13.2 (*c* 6.6, CHCl₃); ¹H NMR (250 MHz, CDCl₃) δ 7.70–7.66 (m, 4H), 7.47–7.35 (m, 6H), 6.31 (dd, *J* = 6.1, 1.7 Hz, 1H, H-1), 4.72 (dd, *J* = 6.1, 2.2 Hz, 1H,

Scheme 9

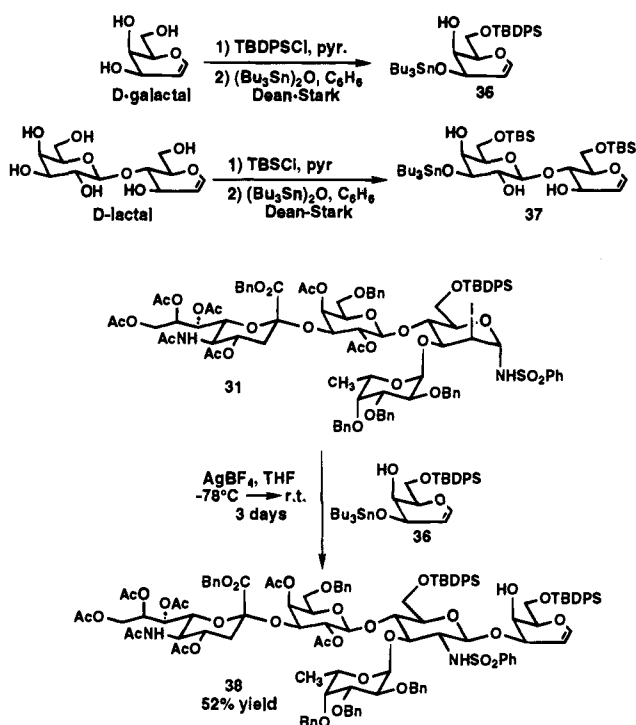

Scheme 10

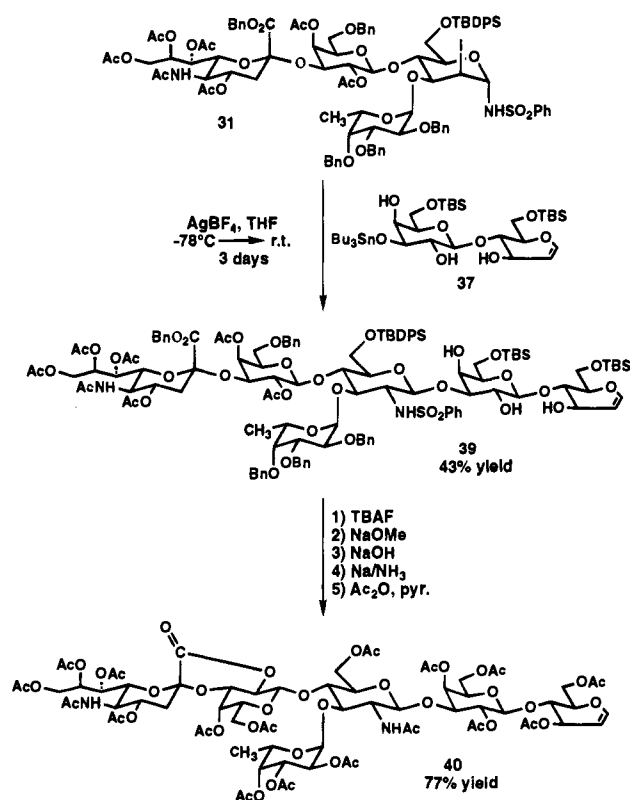

H-2), 4.29–4.24 (m, 1H, H-3), 3.98–3.96 (m, 2H), 3.95–3.76 (m, 2H), 2.74 (d, $J = 3.2$ Hz, 1H, OH), 2.11 (d, $J = 5.6$ Hz, 1H, OH), 1.06 (s, 9H); ^{13}C NMR (62.5 MHz, $CDCl_3$) δ 144.1, 135.45, 135.35, 132.8, 132.6, 129.7, 127.6, 127.58, 102.2, 76.3, 71.3, 69.5, 63.6, 26.6, 19.1; FTIR (CCl_4) 3593, 3403, 3064, 2923, 2853, 1640, 1422, 1224, 1105, 695, 450 cm^{-1} ; HRMS (FAB) calcd for $C_{22}H_{28}O_4SiNa$ ($M + Na$) 407.1655, found 407.1682.

(6-Deoxy-2,3,4-tri-*O*-benzyl- α -L-galactopyranosyl)-(1 \rightarrow 3)-1,5-anhydro-6-*O*-(*tert*-butyldiphenylsilyl)-2-deoxy-D-arabino-hex-1-enopyranose (6). 6-*O*-(*tert*-butyldiphenylsilyl)-D-glucal (7.4 g, 19.3 mmol) and fucosyl fluoride 5 (8.0 g, 18.4 mmol, 1:1 α : β mixture) were placed

in a dry flask and azeotroped three times from benzene. They were then diluted in 50 mL of dry ether and cannulated into a flask containing $AgClO_4$ (11.4 g, 55.2 mmol), $SnCl_2$ (10.5 g, 55.2 mmol), and 2,6-di-*tert*-butylpyridine (25 mL, 21.1 g, 110.4 mmol), and flame dried powdered 4 Å molecular sieves (30 g) suspended in 100 mL of dry ether under a nitrogen atmosphere at room temperature. The mixture was stirred at room temperature for 48 h, after which time it was diluted with 150 mL of ether and filtered through Celite. The resulting solution was transferred to a separatory funnel and washed with 3 \times 100 mL portions of 1 N HCl, 3 \times 100 mL portions of H_2O , and 3 \times 100 mL portions of saturated $NaHCO_3$ solution. The organic layer was dried over $MgSO_4$ and concentrated *in vacuo*. The residue was subjected to flash chromatography using 15:85 ethyl acetate:hexanes to afford 7.6 g (51% yield) of the title compound as a clear oil: $[\alpha]_D^{25} -60.5^\circ$ (c 1.03, $CHCl_3$); FTIR (CCl_4) 3412, 3063, 3026, 2922, 2885, 2848, 1652, 1486, 1449, 1425, 1235, 1136, 1093, 1050, 1026, 731, 695 cm^{-1} ; 1H NMR (490 MHz, $CDCl_3$) δ 7.72–7.71 (4H, m), 7.40, 7.25 (21H, m), 6.40 (1H, d, $J = 6.0$ Hz, H-1 glucal), 4.99 (1H, d, $J = 11.5$ Hz), 4.93 (1H, $J = 3.9$ Hz, H-1 Fuc), 4.88 (1H, d, $J = 11.8$ Hz), 4.84 (1H, d, $J = 12.1$ Hz), 4.77–4.73 (2H, m), 4.66–4.63 (2H, m), 4.21 (1H, d, $J = 2.1$ Hz), 4.12–4.08 (2H, m), 4.05–4.01 (2H, m), 3.97–3.94 (2H, m), 3.92–3.88 (1H, m), 3.78–3.75 (1H, m), 3.70 (1H, d, $J = 2.0$ Hz), 1.14 (3H, d, $J = 6.5$ Hz, H-6 Fuc), 1.04 (9H, s, *tert*-butyl); ^{13}C NMR (62.5 MHz, $CDCl_3$) δ 145.22, 138.96, 138.76, 138.52, 135.67, 133.58, 129.58, 128.40, 128.25, 127.82, 127.68, 127.61, 127.49, 127.43, 100.32, 98.47, 81.03, 79.12, 78.23, 75.03, 73.35, 73.29, 67.74, 67.68, 62.83, 26.83, 19.42, 16.51; HRMS (FAB) calcd for $C_{49}H_{56}NaO_8Si$ 823.3644, found 823.3703.

Methyl 2,3-Di-*O*-benzyl-4-*O*-benzoyl-6-deoxy- α -L-galactopyranoside (11). Fucose methyl glycoside (940 mg, 5.3 mmol) was suspended in 100 mL of toluene. Bis(dibutyltin) oxide (3 mL, 5.8 mmol) was added, and the mixture was refluxed using a Dean–Stark trap for 12 h. The mixture was concentrated to about 50 mL. Benzyl bromide (2.5 mL, 21.2 mmol) was added followed by tetrabutylammonium bromide (3.4 g, 10.6 mmol). Reflux was continued for 6 h. The solvent was removed, and the residue was dissolved in 50 mL of EtOAc. This was washed with 3 \times 30 mL of H_2O and 2 \times 30 mL of brine, then dried over $MgSO_4$, concentrated *in vacuo*, and subjected to flash chromatography, eluting with 25:75 EtOAc:hexanes to give 1.00 g (2.8 mmol, 53% yield) of the known 2,3-di-*O*-benzyl fucoside (10).¹⁸

Compound 10 was dissolved in 15 mL of CH_2Cl_2 and cooled to 0 $^\circ C$. Pyridine (2.3 mL, 28 mmol) was added, followed by benzoyl chloride (0.97 mL, 8.4 mmol). The reaction mixture was stirred for 2 h and allowed to warm to room temperature. The reaction was then quenched by cooling to 0 $^\circ C$, adding 1.5 mL of methanol and stirring for 30 min. The solvent was removed *in vacuo*, and the residue was subjected to flash chromatography, eluting with 20:80 EtOAc:hexanes to give 1.06 g of 11 (82% yield): $[\alpha]_D^{20} -80.1^\circ$ (c 9.2, $CHCl_3$); 1H NMR (250 MHz, $CDCl_3$) δ 8.08 (app d, $J = 7.0$ Hz, 2H), 7.63–7.57 (m, 1H), 7.50–7.44 (m, 2H), 7.38–7.24 (m, 10H), 5.64 (d, $J = 3.2$ Hz, 1H, H-4), 4.88 (d, $J = 12.0$ Hz, 1H), 4.84 (d, $J = 11.5$ Hz, 1H), 4.75 (d, $J = 3.8$ Hz, 1H, H-1), 4.72 (d, $J = 12.2$ Hz, 1H), 4.64 (d, $J = 11.5$ Hz, 1H), 4.17–4.09 (m, 2H, H-3 and H-5), 3.94 (dd, $J = 10.0$, 3.6 Hz, 1H, H-2), 3.45 (s, 3H), 1.20 (d, $J = 6.6$ Hz, 3H, H-6); ^{13}C NMR (62.5 MHz, $CDCl_3$) δ 166.2, 138.3, 138.2, 133.0, 129.9, 129.8, 128.3, 128.25, 128.20, 127.7, 127.67, 127.4, 99.1, 76.3, 74.7, 73.6, 71.8, 71.5, 64.7, 55.4, 16.2; FTIR (CCl_4) 2894, 1718, 1443, 1260, 1105, 1048, 703 cm^{-1} ; HRMS (FAB) calcd for $C_{28}H_{30}O_6Na$ ($M + Na$) 485.1941, found 485.1952. Elem. Anal. Calcd: C, 72.71; H, 6.54. Found: C, 72.57; H, 6.34.

2,3-Di-*O*-benzyl-4-*O*-benzoyl-6-deoxy- α / β -L-galactopyranose. Compound 11 (12.1 g, 26.1 mmol) was suspended in 250 mL of 80% HOAc and 75 mL of 1 M HCl. The mixture was heated to 100 $^\circ C$ for 10 h. The reaction mixture was cooled to room temperature and washed with 3 \times 75 mL of $CHCl_3$. The organic extracts were combined and washed with 2 \times 75 mL of H_2O , 3 \times 75 mL of saturated $NaHCO_3$ solution, and 2 \times 75 mL of H_2O . The organic layer was dried over $MgSO_4$, concentrated *in vacuo*, and subjected to flash chromatography, eluting with 40:60 EtOAc:hexanes to give 8.0 g of the title compound as a 1:1 α : β mixture (68%): $[\alpha]_D^{20} -93.4^\circ$ (c 6.6, $CHCl_3$); 1H NMR (250 MHz, $CDCl_3$) δ 8.16–8.07 (m, 4H), 7.62–7.55 (m, 2H), 7.49–7.42 (m, 4H), 7.37–7.18 (m, 20H), 5.64 (d, $J = 2.7$ Hz, 1H, H-4 α), 5.58 (d, $J = 2.0$

Scheme 11

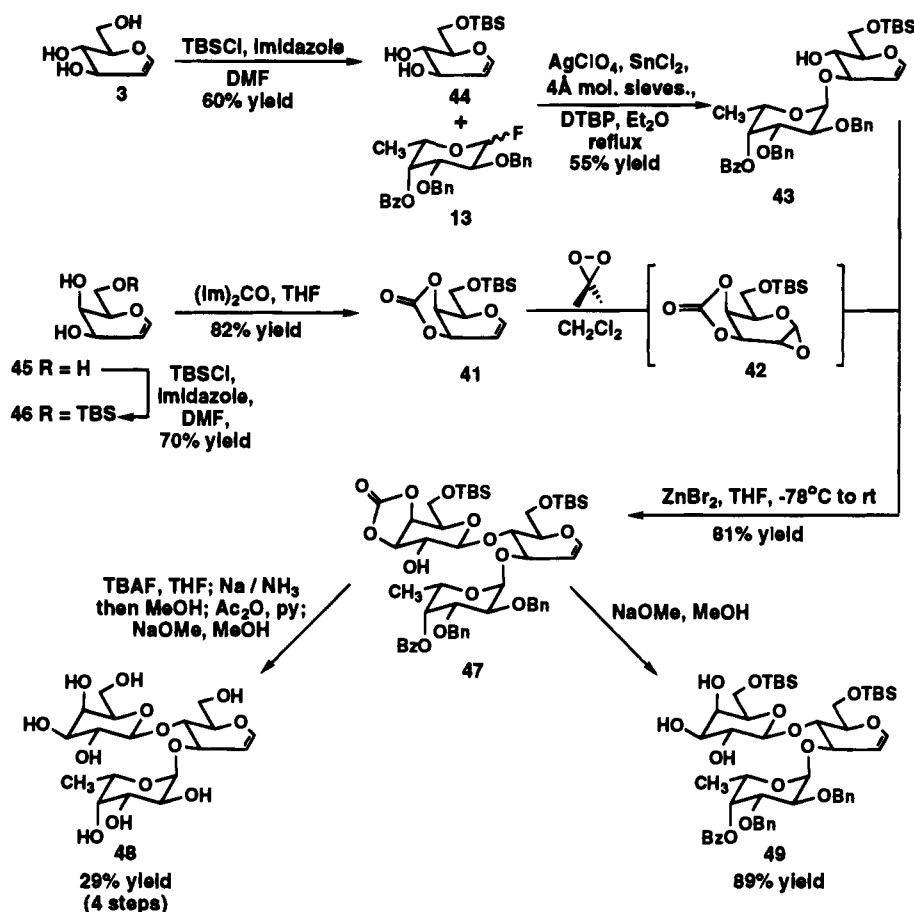

Hz, 1H, H-4 β), 5.33 (d, $J = 3.6$ Hz, 1H, H-1 α), 4.92–4.68 (m, 4H), 4.62–4.56 (m, 4H), 4.37 (br q, $J = 6.5$ Hz, 1H, H-5 α), 4.07 (dd, $J = 9.8, 3.2$ Hz, 1H), 3.91 (dd, $J = 9.8, 3.6$ Hz, 1H, H-2 α), 3.77 (br q, $J = 6.5$ Hz, 1H), 3.69–3.62 (m, 2H), 1.27 (d, $J = 6.4$ Hz, 3H), 1.20 (d, $J = 6.4$ Hz, 3H); ^{13}C NMR (62.5 MHz, CDCl_3) δ 166.3, 166.2, 138.5, 138.0, 137.8, 133.1, 133.0, 129.9, 129.8, 129.7, 128.3, 128.2, 128.0, 127.9, 127.8, 127.6, 127.5, 106.3, 97.2, 92.0, 79.8, 79.4, 76.0, 75.4, 75.1, 73.6, 71.8, 71.5, 71.1, 70.2, 69.5, 65.1, 16.5, 16.3; FTIR (CCl_4) 2922, 1718, 1267, 1105, 1077, 753, 703, 492 cm^{-1} ; HRMS (FAB) calcd for $\text{C}_{27}\text{H}_{28}\text{O}_6\text{Na}$ ($M + \text{Na}$) 471.1784, found 471.1794.

Fluoro-4-*O*-benzoyl-6-deoxy-2,3-di-*O*-benzyl- α/β -L-galactopyranose (13). 4-*O*-Benzoyl-6-deoxy-2,3-di-*O*-benzyl-L-galactopyranose (3.5 g, 7.8 mmol, 1:1 α/β mixture) was dissolved in 75 mL of dry THF and cooled to -30°C under a nitrogen atmosphere. DAST (1.1 mL, 1.3 g, 8.2 mmol) was added and the cooling bath removed. After 5 min at room temperature, TLC indicated complete reaction. The reaction mixture was cooled to -30°C , and 1 mL of methanol was added. After 5 min, the solvent was removed *in vacuo*. The residue was dissolved in 75 mL of ethyl acetate and washed with 3×30 mL portions of brine. The organic layer was dried over MgSO_4 and concentrated *in vacuo*. The residue was subjected to flash chromatography, eluting with 15:85 ethyl acetate:hexanes to afford 3.5 g (99% yield) of 13 as a 1:6 α/β mixture of anomers.

α Anomer: $[\alpha]_D^{25} -79.4^\circ$ (c 0.77, CHCl_3); FTIR (CCl_4) 1718, 1260, 1098, 703, 492 cm^{-1} ; ^1H NMR (250 MHz, CDCl_3) δ 8.03 (2H, app d, $J = 7.0$ Hz), 7.59 (1H, app t, $J = 7.3$ Hz), 7.45 (2H, app t, $J = 7.3$ Hz), 7.35–7.24 (10H, m), 5.67 (1H, d, $J = 2.4$ Hz, H-4), 5.63 (1H, dd, $J = 11.4$ Hz, OCHHPH), 4.70 (1H, d, $J = 11.8$ Hz, OCHHPH), 4.60 (1H, d, $J = 11.5$ Hz, OCHHPH), 4.31 (1H, q, $J = 6.5$ Hz, H-5), 4.08 (1H, dd, $J = 10.0, 3.2$ Hz, H-3), 3.89 (1H, ddd, $J = 25.1, 10.0, 2.7$ Hz, H-2), 1.21 (3H, d, $J = 6.5$ Hz, H-6); ^{13}C NMR (62.5 MHz, CDCl_3) δ 166.0, 138.0, 137.9, 133.1, 129.8, 128.43, 128.37, 128.30, 128.23, 128.17, 128.0, 127.8, 127.6, 108.3, 104.7, 75.8, 74.8, 74.4, 73.8, 71.9, 70.7, 67.7, 67.6, 16.3; HRMS (FAB) calcd for $\text{C}_{27}\text{H}_{27}\text{FNaO}_5$ 473.1741, found 473.1765.

β Anomer: $[\alpha]_D^{25} -107.3^\circ$ (c 0.59, CHCl_3); FTIR (CCl_4) 3077, 3056, 3028, 2979, 2873, 1718, 1267, 1112, 710, 493 cm^{-1} ; ^1H NMR (250 MHz, CDCl_3) δ 8.17 (2H, app d, $J = 7.0$ Hz), 7.63 (1H, app t, $J = 7.3$ Hz), 7.50 (1H, app t, $J = 7.1$ Hz), 7.43–7.28 (10H, m), 5.62 (1H, d, $J = 2.5$ Hz, H-4), 5.29 (1H, dd, $J = 52.8, 7.0$ Hz, H-1), 4.90 (1H, d, $J = 10.8$ Hz, OCHHPH), 4.86 (1H, d, $J = 10.5$ Hz, OCHHPH), 4.82 (1H, d, $J = 10.7$ Hz, OCHHPH), 4.62 (1H, d, $J = 11.6$ Hz, OCHHPH), 3.92–3.80 (2H, m), 3.73 (1H, dd, $J = 9.8, 3.2$ Hz, H-3), 1.36 (3H, d, $J = 6.4$ Hz, H-6); ^{13}C NMR (62.5 MHz, CDCl_3) δ 166.0, 138.0, 137.6, 133.2, 129.9, 129.7, 128.4, 128.2, 128.0, 127.9, 127.7, 111.6, 108.3, 78.7, 78.5, 78.4, 75.0, 72.0, 69.8, 69.7, 69.6, 16.3; HRMS (FAB) calcd for $\text{C}_{27}\text{H}_{27}\text{FNaO}_5$ 473.1741, found 473.1739.

(4-*O*-Benzoyl-6-deoxy-2,3-di-*O*-benzyl- α -L-galactopyranosyl)-(1 \rightarrow 3)-1,5-anhydro-6-*O*-(*tert*-butyldiphenylsilyl)-2-deoxy-D-*arabino*-hex-1-enopyranose (14). 6-*O*-(*tert*-Butyldiphenylsilyl)-D-glucal (4) (378 mg, 1.0 mmol) and fucosyl fluoride 13 (298 mg, 0.7 mmol, 1:6 α/β mixture) were placed in a dry flask and azeotroped three times from benzene. They were then diluted in 7 mL of dry ether and cannulated into a dry flask containing AgClO_4 (274 mg, 1.3 mmol), SnCl_2 (250 mg, 1.3 mmol), 2,6-di-*tert*-butylpyridine (0.45 mL, 380 mg, 2.0 mmol), and flame dried powdered 4 \AA molecular sieves (1 g) under a nitrogen atmosphere. The mixture was refluxed for 48 h, after which time it was diluted with 20 mL of ether and filtered through Celite. The resulting solution was transferred to a separatory funnel and washed with 3×10 mL portions of 1 N HCl then 3×10 mL portions of saturated NaHCO_3 solution. The organic layer was dried over MgSO_4 and concentrated *in vacuo*. The residue was subjected to flash chromatography, eluting with 15:85 ethyl acetate:hexanes to afford 318 mg (59% yield) of the title compound as a white foam: $[\alpha]_D^{25} -85.8^\circ$ (c 0.69, CHCl_3); FTIR (CCl_4) 3432, 3062, 3031, 2920, 2852, 1718, 1651, 1601, 1583, 1453, 1423, 1269, 1096, 1053, 1022, 732, 689 cm^{-1} ; ^1H NMR (490 MHz, CDCl_3) δ 8.04 (2H, app d), 7.70 (2H, app d), 7.57 (1H, app t), 7.46–7.19 (10H, m), 6.40 (1H, dd, $J = 6.0, 1.7$ Hz, H-1 glucal), 5.64 (1H, d, $J = 2.4$ Hz, H-4 Fuc), 5.00 (1H, d, $J = 3.8$ Hz, H-1 Fuc), 4.83 (1H, d, $J = 12.0$ Hz, OCHHPH), 4.79 (1H, d, $J = 11.3, \text{OCHHPH}$), 4.77 (1H, dd, $J = 6.0, 2.0$ Hz, H-2 Glucal), 4.63 (1H,

$d, J = 12.1$ Hz, OCHHPh), 4.59 (1H, $d, J = 11.3$ Hz, OCHHPh), 4.38 (1H, $q, J = 6.6$ Hz, H-5 Fuc), 4.15–4.13 (1H, m), 4.11 (1H, $dd, J = 10.1, 3.3$ Hz, H-4 glucal), 4.04 (1H, $dd, J = 11.3, 3.8$ Hz, H-2 Fuc), 3.98–3.94 (3H, m), 3.87 (1H, OH, $d, J = 2.5$ Hz), 3.81–3.78 (1H, m), 1.17 (3H, $d, J = 6.6$ Hz, H-6 Fuc), 1.05 (9H, s , *tert*-butyl); ^{13}C NMR (62.5 MHz, CDCl_3) δ 166.2, 145.4, 138.6, 138.3, 135.7, 135.6, 133.6, 133.5, 133.1, 130.1, 129.9, 129.7, 128.4, 128.2, 127.9, 127.74, 127.66, 127.4, 100.0, 98.1, 80.2, 78.2, 77.2, 76.2, 75.2, 73.4, 71.9, 71.4, 67.9, 66.1, 63.0, 26.8, 19.4, 16.2; HRMS (FAB) calcd for $\text{C}_{49}\text{H}_{54}\text{NaO}_9\text{Si}$ 837.3436, found 837.3499. Anal. Calcd for $\text{C}_{49}\text{H}_{54}\text{O}_9\text{Si}$: C, 72.21; H, 6.68. Found: C, 71.91; H, 6.69.

6-*O*-Benzyl-1,2,3,4-tetra-*O*-benzoyl- α -D-galactopyranose (18). 1,2:3,4-Di-*O*-isopropylidene-6-*O*-benzyl-D-galactopyranose (35.03 g, 100.0 mmol)²⁰ was hydrolyzed as reported by Anet²¹ to provide crude 6-*O*-benzyl- α -D-galactopyranose (17) as an off-white solid which was used crude since attempted purification resulted in partial anomerization.

Pyridine (110 mL, 1.36 mol) was diluted in chloroform (45 mL) and cooled to -10 °C (internal temperature). A solution of benzoyl chloride (90 mL, 0.78 mol) was slowly added, maintaining the temperature below 5 °C. After the internal temperature was returned to -10 °C, 17 (28.1 g) was added slowly, keeping the internal temperature below 0 °C. (Addition of 17 is accompanied by a vigorous exotherm which, if not controlled, will result in formation of the anomeric β benzoate.) After addition was complete, the reaction was stirred at 0 °C for 6 h, then slowly warmed to room temperature overnight. The reaction mixture was diluted with chloroform (300 mL), washed three times with 3 N aqueous H_2SO_4 , once with saturated aqueous sodium bicarbonate, and once with water. After standing over sodium sulfate, the reaction solution was evaporated to a yellow oil. Flash chromatography in two batches (6:1 heptane:ethyl acetate, gradient elution to 3:1) and evaporation of solvents provided 18 (63.24 g, 92%) as a white solid: mp 59–61 °C; $[\alpha]_{\text{D}}^{19} +157.3$ (c 0.515, CHCl_3); IR (CCl_4) 3040, 3010, 2900, 2850, 1730, 1590, 1575, 1540, 1480, 1445, 1260, 1100, 710 cm^{-1} ; ^1H NMR (490 MHz, CDCl_3) δ 8.11 (2H, $dd, J = 8.1, 1.3$ Hz), 8.06 (2H, $dd, J = 8.2, 1.2$ Hz), 7.84 (2H, $dd, J = 8.4, 1.2$ Hz), 7.82 (2H, $dd, J = 8.4, 1.2$ Hz), 7.63 (2H, m), 7.53–7.48 (5H, m), 7.46–7.42 (2H, m), 7.29–7.14 (8H, m), 6.90 (1H, $d, J = 3.6$ Hz), 6.15 (1H, $dd, J = 3.4, 1.2$ Hz), 6.07 (1H, $dd, J = 10.7, 3.3$ Hz), 5.96 (1H, $dd, J = 10.7, 3.6$ Hz), 4.66 (1H, $t, J = 6.9$ Hz), 4.49, 4.38 (2H, AB $q, J = 11.8$ Hz), 3.68–3.62 (2H, m); ^{13}C NMR (63 MHz, CDCl_3) δ 165.6, 165.3, 164.5, 137.2, 133.7, 133.4, 133.3, 133.1, 129.8, 129.6, 129.2, 129.1, 129.0, 128.7, 128.6, 128.5, 128.4, 128.2, 127.8, 127.6, 90.7, 73.6, 70.6, 68.7, 67.9, 67.4; MS (FAB, m/e) 579, 567, 566, 565, 353, 307; HRFAB ($M + \text{Na}$) calcd 709.2050, found 709.2109. Anal. Calcd for $\text{C}_{41}\text{H}_{34}\text{O}_{10}$: C, 71.71; H, 4.99. Found: C, 71.64; H, 4.95.

2,3,4-Tri-*O*-benzoyl-6-*O*-benzylgalactopyranose (19). A mixture of tetrahydrofuran (210 mL) and methanol (90 mL) was cooled to 0 °C, and ammonia gas was bubbled through the solution for 10 min. Compound 18 (14.42 g, 21.00 mmol) was then added, and the reaction was slowly allowed to warm to room temperature. Reaction progress was monitored by TLC until the ratio of starting material to product was judged to be 1:1. (Reaction beyond this point resulted in lower yields due to debenzoylation at other oxygens.) At this point (generally 48 h), the volatiles were removed by rotary evaporation and the residue was purified by flash chromatography (3:1 heptane:ethyl acetate) to provide recovered 18 (6.98 g, 48%) and product 19 (5.04 g, 41%, 4:1 mixture of equilibrating β and α anomers) as a white solid: mp 71–71 °C; $[\alpha]_{\text{D}}^{19} +124.3$ (c 1.15, CHCl_3); IR (CCl_4) 3420, 3050, 3020, 2910, 2860, 1730, 1600, 1585, 1490, 1450, 1270, 1100, 710 cm^{-1} ; ^1H NMR (490 MHz, CDCl_3 , β anomer) δ 8.05 (2H, $dd, J = 8.1, 1.3$ Hz), 7.99 (2H, $dd, J = 8.2, 1.3$ Hz), 7.80 (2H, $dd, J = 8.1, 1.2$ Hz), 7.58 (1H, $t, J = 8.6$ Hz), 7.47–7.43 (3H, m), 7.39 (1H, m), 7.32 (2H, $t, J = 7.8$ Hz), 7.25–7.19 (7H, m), 6.02 (1H, $dd, J = 10.6, 3.4$), 5.91 (1H, m), 5.81 (1H, $br s$), 5.68 (1H, $dd, J = 10.7, 3.5$ Hz), 4.72 (1H, $t, J = 6.8$ Hz), 4.52, 4.40 (2H, AB $q, J = 12.0$ Hz), 4.39 (1H, m , disappears on D_2O treatment), 3.63, 3.58 (2H, ABX $ddd, J = 9.8, 7.4, 4.9$ Hz); MS (FAB, m/e) 566, 565, 475, 461, 353, 220, 205, 181, 165; HRFAB (M^+) calcd 583.1968, found 583.1995. Anal. Calcd for $\text{C}_{34}\text{H}_{30}\text{O}_9$: C, 70.09; H, 5.19. Found: C, 70.01; H, 5.11.

2,3,4-Tri-*O*-benzoyl-6-*O*-benzyl- β -D-galactopyranosyl Trichloroacetimidate (20). To a suspension of K_2CO_3 (2.6 g, 18.5 mmol) in

50 mL of dry CH_2Cl_2 at room temperature under a nitrogen atmosphere was added 2,3,4-tri-*O*-benzoyl-6-*O*-benzyl-D-galactose (2.7 g, 4.6 mmol) followed by trichloroacetonitrile (4.6 mL, 6.6 g, 46 mmol). The mixture was stirred for 1 h, after which time the K_2CO_3 was removed by filtration and the solvent and excess Cl_3CCN were removed *in vacuo*. The residue was subjected to flash chromatography, eluting with 30:70 ethyl acetate:hexanes to afford 0.7 g (20% yield) of α -galactosyl trichloroacetimidate as a white solid and 2.4 g (70% yield) of the title compound as a clear oil.

β anomer: $[\alpha]_{\text{D}}^{25} +140.4$ (c 1.0, CHCl_3); FTIR (CCl_4) 3331, 3084, 3063, 3028, 2979, 2915, 2866, 1731, 1668, 1605, 1591, 1492, 1443, 1372, 1316, 1260, 1210, 1168, 1084, 1027, 901, 830 cm^{-1} ; ^1H NMR (250 MHz, CDCl_3) δ 8.76 (1H, s, NH), 8.15–7.12 (20H, m), 6.21 (1H, $d, J = 8.2$ Hz, H-1), 6.07 (1H, $d, J = 3.4$ Hz, H-4), 6.04 (1H, $dd, J = 10.3, 8.2$ Hz, H-2), 5.70 (1H, $dd, J = 10.3, 3.4$ Hz, H-3), 4.56 (1H, $d, J = 11.9$ Hz, OCHHPh), 4.48 (1H, $d, J = 12.0$ Hz, OCHHPh), 4.38 (1H, $m, H-5$), 3.79–3.66 (2H, $m, H-6, H-6'$); ^{13}C NMR (62.5 MHz, CDCl_3) δ 165.2, 161.0, 137.1, 133.2, 133.0, 129.7, 129.5, 129.4, 129.0, 128.9, 128.6, 129.3, 129.1, 128.0, 127.6, 127.5, 96.3, 90.1, 76.3, 73.6, 73.3, 71.5, 68.7, 67.8, 67.0; HRMS (FAB) calcd for $\text{C}_{36}\text{H}_{30}\text{Cl}_3\text{NNaO}_9$ 750.0840, found 750.0863.

[(6-Deoxy-2,3,4-tri-*O*-benzyl- α -L-galactopyranosyl)-(1 \rightarrow 3)]-[(2,3,4-tri-*O*-benzoyl-6-*O*-benzyl- β -D-galactopyranosyl)-(1 \rightarrow 4)]-1,5-anhydro-6-*O*-(*tert*-butyldiphenylsilyl)-2-deoxy-D-*arabino*-hex-1-enopyranose (23). β -D-Galactopyranosyl trichloroacetimidate 20 (850 mg, 1.2 mmol) and disaccharide 6 (1.03 g, 1.3 mmol) were dissolved in 12 mL of dry CH_2Cl_2 and stirred over 4 Å molecular sieves (beads, 3 g) under a nitrogen atmosphere at room temperature for 2 h. The mixture was then cooled to -78 °C, and $\text{BF}_3\cdot\text{OEt}_2$ (14 μL , 16 mg, 0.12 mmol) was added. The mixture was stirred for 4 h, during which time the temperature warmed to 0 °C. The reaction mixture was then filtered, transferred to a separatory funnel, and washed with 3 \times 5 mL portions of saturated NaHCO_3 . The organic layer was dried over MgSO_4 then the solvent removed *in vacuo*. The residue was subjected to flash chromatography, eluting with 15:85 ethyl acetate:hexanes to afford 1.2 g (75% yield) of the title compound as a white foam: $[\alpha]_{\text{D}}^{25} -22.6$ (c 0.80 CHCl_3); FTIR (CCl_4) 1732, 1274, 1253, 1098, 1063, 703 cm^{-1} ; ^1H NMR (490 MHz, CDCl_3) δ 7.99–7.10 (45H, m), 6.31 (1H, $d, J = 6.2$ Hz, H-1 glucal), 5.94 (1H, $d, J = 3.4$ Hz, H-4 Gal), 5.71 (1H, $dd, J = 10.4, 8.1$ Hz, H-2 Gal), 5.47 (1H, $dd, J = 10.4, 3.4$ Hz, H-3 Gal), 5.24 (1H, $d, J = 8.1$ Hz, H-1 Gal), 4.87 (1H, $d, J = 11.5$ Hz, OCHHPh), 4.85 (1H, $d, J = 3.4$ Hz, H-1 Fuc), 4.76 (1H, $d, J = 11.8$ Hz, OCHHPh), 4.74 (1H, $d, J = 10.2$ Hz, OCHHPh), 4.67 (1H, $dd, J = 6.2, 1.7$ Hz, H-2 glucal), 4.63 (1H, $d, J = 12.3$ Hz), 4.59 (1H, $q, J = 6.5$ Hz, H-5 Fuc), 4.52 (1H, $d, J = 11.5$ Hz, OCHHPh), 4.47–4.39 (4H, m), 4.31, (1H, $d, J = 12.0$), 4.04–3.97 (3H, m), 3.94 (1H, $dd, J = 11.9, 2.2$ Hz), 3.86 (1H, $dd, J = 11.9, 2.2$ Hz), 3.71 (1H, $dd, J = 9.2, 5.5$ Hz), 3.62–3.56 (3H, m), 1.36 (3H, $d, J = 6.5$ Hz, H-6 Fuc), 1.12 (9H, $s, tert$ -butyl); ^{13}C NMR (62.5 MHz, CDCl_3) δ 165.6, 165.2, 164.8, 144.5, 139.0, 138.9, 138.6, 137.4, 135.9, 135.4, 133.6, 133.4, 133.0, 132.6, 130.2, 129.8, 129.7, 129.66, 129.54, 129.48, 128.9, 128.5, 128.3, 128.2, 128.1, 128.0, 127.9, 127.8, 127.7, 127.6, 127.5, 127.3, 127.0, 100.1, 99.1, 94.7, 80.0, 79.2, 77.7, 77.1, 76.0, 74.9, 73.5, 73.0, 72.4, 72.0, 71.7, 70.1, 69.9, 68.6, 67.2, 66.3, 61.0, 27.0, 19.4, 16.6; HRMS (FAB) calcd for $\text{C}_{83}\text{H}_{84}\text{NaO}_{16}\text{Si}$ 1387.5426, found 1387.5508.

[(4-*O*-Benzoyl-6-deoxy-2,3-di-*O*-benzyl-4- α -L-galactopyranosyl)-(1 \rightarrow 3)]-[(2,3,4-tri-*O*-benzoyl-6-*O*-benzyl- β -D-galactopyranosyl)-(1 \rightarrow 4)]-1,5-anhydro-6-*O*-(*tert*-butyldiphenylsilyl)-2-deoxy-D-*arabino*-hex-1-enopyranose (22). β -Galactosyl trichloroacetimidate 20 (405 mg, 0.56 mmol) and disaccharide 14 (412 mg, 0.51 mmol) were dissolved in 5 mL of dry CH_2Cl_2 and stirred over 4 Å molecular sieves (beads, 1.5 g) under a nitrogen atmosphere at room temperature for 2 h. The mixture was then cooled to -78 °C, and $\text{BF}_3\cdot\text{Et}_2\text{O}$ (6 μL , 7.2 mg, 0.05 mmol) was added. The mixture was stirred at -78 °C for 5 h. The reaction mixture was then diluted with 10 mL of CH_2Cl_2 and filtered. The resulting solution was transferred to a separatory funnel and washed with 3 \times 5 mL portions of saturated NaHCO_3 . The organic layer was dried over MgSO_4 and concentrated *in vacuo*. The residue was subjected to flash chromatography, eluting with 25:75 ethyl acetate:hexanes to afford 428 mg (61% yield) of the title compound as a white foam: $[\alpha]_{\text{D}}^{25} -44.4$ (c 1.57, CHCl_3); FTIR (CCl_4) 3058, 3033, 2918, 2854, 1724, 1450, 1277, 1258, 1098, 1060, 1022, 741, 696 cm^{-1} ; ^1H

NMR (490 MHz, CDCl₃) δ 8.08 (2H, d, $J = 7.3$ Hz), 7.94 (2H, d, $J = 7.1$ Hz), 7.81–7.76 (6H, m), 7.62–7.39 (19H, m), 7.29–7.07 (16H, m), 6.36 (1H, d, $J = 6.0$ Hz, H-1 glucal), 5.97 (1H, d, $J = 3.7$ Hz, H-4 Gal), 5.72 (1H, d, $J = 2.8$ Hz, H-4 Fuc), 5.67 (1H, dd, $J = 10.4, 8.3$ Hz, H-2 Gal), 5.51 (1H, dd, $J = 10.5, 3.7$ Hz, H-3 Gal), 5.29 (1H, d, $J = 8.2$ Hz, H-1 Gal), 4.91 (1H, d, $J = 3.1$ Hz, H-1 Fuc), 4.92–4.90 (1H, m), 4.82 (1H, d, $J = 12.3$ Hz), 4.74 (1H, dd, $J = 6.1, 1.9$ Hz, H-2 glucal), 4.72 (1H, d, $J = 10.8$ Hz), 4.64 (1H, d, $J = 12.3$ Hz), 4.52–4.43 (2H, m), 4.44 (1H, d, $J = 10.6$ Hz), 4.42 (1H, d, $J = 12.0$ Hz), 4.33 (1H, d, $J = 12.0$ Hz), 4.17 (1H, dd, $J = 10.0, 3.1$ Hz, H-2 Fuc), 4.06 (1H, app t), 3.98–3.92 (2H, m), 3.87 (1H, dd, $J = 11.9, 1.7$ Hz), 3.75 (1H, dd, $J = 8.9, 5.4$ Hz), 3.67 (1H, app t, $J = 8.6$ Hz), 3.58 (1H, app d, $J = 9.3$ Hz), 1.31 (3H, d, $J = 6.5$ Hz, H-6 Fuc), 1.15 (9H, s, *tert*-butyl); ¹³C NMR (62.5 MHz, CDCl₃) δ 166.1, 165.8, 165.3, 164.8, 144.8, 138.6, 138.4, 137.4, 136.0, 135.5, 133.6, 133.4, 133.0, 132.9, 132.8, 130.4, 130.2, 129.9, 129.8, 129.6, 129.2, 129.1, 128.8, 128.3, 128.1, 127.8, 127.72, 127.67, 127.5, 127.4, 100.4, 99.0, 95.2, 77.9, 77.4, 74.8, 73.6, 72.6, 72.3, 72.0, 71.9, 71.7, 70.9, 69.9, 68.3, 67.2, 65.0, 61.1, 27.1, 19.5, 16.3; HRMS (FAB) calcd for C₈₃H₈₂NaO₁₇Si 1401.5219, found 1401.5246.

[(6-Deoxy-2,3,4-tri-*O*-benzyl- α -L-galactopyranosyl)-(1 \rightarrow 3)]-[(6-*O*-benzyl- β -D-galactopyranosyl)-(1 \rightarrow 4)]-1,5-anhydro-6-*O*-(*tert*-butyldiphenylsilyl)-2-deoxy-D-*arabino*-hex-1-enopyranose (24). Sodium (50 mg) was dissolved in 100 mL of dry methanol at 0 °C under a nitrogen atmosphere. Trisaccharide **23** (1.03 g, 0.9 mmol) dissolved in 10 mL of dry CH₂Cl₂ was added, and the mixture was stirred at 0 °C for 5 h. The solvent was evaporated and the residue subjected to flash chromatography, eluting with 70:30 benzene:acetone to afford 730 mg (97% yield) of the title compound as a white foam: $[\alpha]_D^{25}$ -45.0° (*c* 1.4, CHCl₃); FTIR (CCl₄) 3401, 3060, 3019, 2917, 2845, 1639, 1496, 1448, 1371, 1096, 1054, 1036, 738, 696 cm⁻¹; ¹H NMR (490 MHz, CDCl₃) δ 7.68–7.66 (4H, m), 7.39–7.19 (26H, m), 6.34 (1H, d, $J = 5.9$ Hz, H-1 glucal), 4.91 (1H, d, $J = 11.5$ Hz), 4.84 (1H, d, $J = 3.6$ Hz, H-1 Fuc), 4.81 (1H, d, $J = 11.6$ Hz), 4.74 (1H, d, $J = 12.0$ Hz), 4.71 (1H, d, $J = 6.2$ Hz), 4.65–4.61 (4H, m), 4.54 (1H, d, $J = 12.0$ Hz), 4.44 (1H, d, $J = 12.0$ Hz, OCHHPh), 4.40 (1H, d, $J = 11.9$ Hz, OCHHPh), 4.38–4.32 (4H, m), 4.16 (1H, dd, $J = 11.7, 3.1$ Hz), 4.00 (1H, dd, $J = 10.1, 3.7$ Hz), 3.96–3.93 (4H, m), 3.89 (1H, dd, $J = 10.2, 3.7$ Hz), 3.85–3.84 (1H, m), 3.70 (1H, dd, $J = 9.4, 6.9$ Hz, H-2 Gal), 3.62 (1H, dd, $J = 9.4, 5.0$ Hz, H-3 Gal), 3.58 (1H, d, $J = 2.5$ Hz), 3.54–3.50 (1H, m), 3.44 (1H, app t, $J = 5.9$ Hz, H-3 glucal), 3.39–3.35 (1H, m), 2.54–2.51 (2H, m), 2.43 (1H, app d), 1.05 (9H, s, *tert*-butyl), 1.04 (3H, d, $J = 7.9$ Hz, H-6 Fuc); ¹³C NMR (62.5 MHz, CDCl₃) δ 144.78, 135.87, 135.61, 129.72, 128.49, 128.28, 128.16, 128.09, 127.83, 127.70, 127.60, 127.46, 127.40, 127.29, 127.11, 101.40, 95.46, 79.61, 78.31, 78.06, 74.91, 73.51, 73.40, 73.33, 73.05, 72.78, 72.41, 72.22, 71.42, 68.32, 66.42, 61.80, 26.90, 19.42, 16.57; HRMS (FAB) calcd for C₆₂H₇₀NaO₁₃Si 1073.4522, found 1073.4472.

[(6-*O*-Benzyl- β -D-galactopyranosyl)-(1 \rightarrow 4)]-[(4-*O*-benzoyl-6-deoxy-2,3-di-*O*-benzyl- α -L-galactopyranosyl)-(1 \rightarrow 3)]-1,5-anhydro-6-*O*-(*tert*-butyldiphenylsilyl)-2-deoxy-D-*arabino*-hex-1-enopyranose (25). Trisaccharide **22** (1.21 g, 0.90 mmol) was dissolved in methanol (10 mL). Sodium methoxide (0.2 mL, 25 % solution in methanol, Aldrich) was added, and the reaction was allowed to stir at room temperature. After 24 h, the reaction was judged complete by TLC. The methanol was evaporated, and the residue was chromatographed (7:3 benzene:acetone) to afford **25** (711 mg, 76% yield): $[\alpha]_D^{25} +242.3^\circ$ (*c* 3.00, CH₃OH); IR (neat) 3398, 3064, 3030, 2928, 2854, 1738, 1721, 1647, 1534, 1262, 1109, 1069, 729, 695 cm⁻¹; ¹H NMR (490 MHz, CDCl₃) δ 8.02 (2H, d, $J = 8.0$ Hz), 7.71–7.68 (4H, m), 7.56 (1H, t, $J = 6.8$ Hz), 7.44–7.21 (23H, m), 6.40 (1H, d, $J = 6.0$ Hz), 5.60 (1H, d, $J = 2.9$ Hz), 4.91 (1H, d, $J = 3.6$ Hz), 4.80–4.73 (4H, m), 4.71 (1H, d, $J = 7.8$ Hz), 4.63 (1H, d, $J = 12.2$ Hz), 4.55–4.52 (2H, m), 4.44–4.40 (3H, m), 4.21 (1H, d, $J = 9.2$ Hz), 4.07 (1H, dd, $J = 10.1, 3.2$ Hz), 3.99–3.94 (2H, m), 3.90–3.86 (2H, m), 3.76, 3.66 (2H, ABX dq, $J = 9.4, 7.0, 5.1$ Hz), 3.54 (1H, t, $J = 8.0$ Hz), 3.46 (1H, t, $J = 6.0$ Hz), 3.36 (1H, dd, $J = 9.5, 3.3$ Hz), 1.09 (3H, d, $J = 6.5$ Hz), 1.07 (9H, s); ¹³C NMR (63 MHz, CDCl₃) δ 166.4, 145.0, 138.5, 135.9, 135.6, 133.6, 132.92, 132.87, 130.2, 129.84, 129.76, 128.5, 128.2, 127.8, 127.7, 127.63, 127.57, 127.3, 101.4, 99.4, 95.7, 78.2, 76.9, 74.9, 73.5, 72.7, 72.5, 72.0, 71.9, 71.8, 71.6, 68.2, 68.1, 65.0, 61.6, 26.9, 19.5, 16.2; MS (FAB-NOBA, *m/e*) 1090, 1089, 432, 431, 349, 311, 309, 293, 290,

289, 271, 269, 259, 253, 251, 241, 240, 239, 233, 221, 211, 201; HRMS (FAB) calcd for C₆₂H₇₀NaO₁₄Si 1089.4434, found 1089.4455. Anal. Calcd for C₆₂H₇₀O₁₄Si: C, 69.77; H, 6.61. Found: C, 69.72; H, 6.70.

[(Benzyl 5-acetamido-4,7,8,9-tetra-*O*-acetyl-3,5-dideoxy-*O*-glycero- α -D-galacto-2-nonulopyranosylate)-(2 \rightarrow 3)]-(2,4-di-*O*-acetyl-6-*O*-benzyl- β -D-galactopyranosyl)-(1 \rightarrow 4)]-[(6-deoxy-2,3,4-tri-*O*-benzyl- α -L-galactopyranosyl)-(1 \rightarrow 3)]-1,5-anhydro-6-*O*-(*tert*-butyldiphenylsilyl)-2-deoxy-D-*arabino*-hex-1-enopyranose (27). The trisaccharide **24** (980 mg, 0.93 mmol), silver triflate (257 mg, 1.0 mmol), 2,6-di-*tert*-butylpyridine (245 μ L, 1.0 mmol), and calcium sulfate (1 g) were diluted in 4 mL of THF and stirred at room temperature for 30 min. The reaction mixture was cooled to -78 °C, and sialic acid donor **26** (500 mg, 1.0 mmol, in 1 mL of THF) was added dropwise over 1 h. After the addition was complete, the temperature was warmed to -55 °C for 1 h, then again cooled to -78 °C before addition of the second portion of silver triflate (257 mg, 1.0 mmol), 2,6-di-*tert*-butylpyridine (25 μ L, 1.0 mmol), and **26** (500 mg, 1.0 mmol, in 1 mL of THF), which was again added dropwise over 1 h. After the addition was complete, the reaction mixture was warmed to -55 °C for 1 h, then allowed to slowly warm to -10 °C overnight. The reaction mixture was quenched by filtration through Celite, concentration, and flash column chromatography, eluting with 7:3 benzene:acetone to give a mixture of the starting material, the 2,3-dehydrosialyl derivative, and the desired product, which were subjected to acetylation in dichloromethane with acetic anhydride, pyridine, and catalytic DMAP for 12 h. The reaction mixture was concentrated and subjected to medium-pressure liquid chromatography (LiChroprep Si 60 40-63 mm), eluting with 2:1:0.1 ethyl acetate:hexanes:acetone to afford the tetrasaccharide glycal **27** as a pure white solid in 38% yield, 78% based on recovered starting material: $[\alpha]_D^{25} -24.3^\circ$ (*c* 0.91, CHCl₃); IR (neat) 3339, 3076, 3027, 2929, 2862, 1745, 1678, 1641, 1452, 1421, 1354, 1226, 1104, 1073, 1030, 731, 694 cm⁻¹; ¹H NMR (62.5 MHz, CDCl₃) δ 7.62–7.95 (5H), 7.38–7.25 (31H), 6.22 (1H, d, $J = 6.2$ Hz, H-1 glucal), 5.39 (1H, m, H-8 NeuAc), 5.34 (1H, d, $J = 12.0$ Hz, OCHHPh), 5.27 (1H, dd, $J = 8.6, 2.5$ Hz, H-7 NeuAc), 5.12 (1H, d, $J = 3.3$ Hz, H-4 Gal), 4.93 (1H, d, $J = 12.0$ Hz, OCHHPh), 4.92 (1H, t, $J = 8.0$ Hz, H-2 Gal), 4.90–4.78 (5H, including H-4 NeuAc), 4.75 (1H, d, $J = 8.0$ Hz, H-1 Gal), 4.71 (1H, dd, $J = 6.2, 4.5$ Hz, H-2 Glucal), 4.58 (1H, d, $J = 12.0$ Hz, OCHHPh), 4.53 (1H, dd, $J = 8.0, 3.3$ Hz, H-3 Gal), 4.50 (1H, d, $J = 11.8$ Hz, OCHHPh), 4.44 (1H, d, $J = 12.5$ Hz, OCHHPh), 4.40 (2H), 4.37 (1H, d, $J = 12.5$ Hz, OCHHPh), 4.33 (1H, d, $J = 11.8$ Hz, OCHHPh), 4.27 (1H, dd, $J = 12.3, 2.1$ Hz, H-9 NeuAc), 4.23 (1H, m), 4.02–3.91 (5H, including H-5 NeuAc), 3.85 (1H, td, $J = 10.7, 3.4$ Hz, H-4 glucal), 3.78 (1H, m), 3.74 (1H, q, $J = 6.5$ Hz, H-5 Fuc), 3.58 (1H, dd, $J = 10.1, 2.6$ Hz, H-5 glucal), 3.46–3.42 (2H, m), 3.36–3.31 (2H, m), 2.53 (1H, dd, $J = 12.6, 4.6$ Hz, H-3eq NeuAc), 2.08 (3H, s, CH₃CO), 2.05 (3H, s, CH₃CO), 1.98 (3H, s, CH₃CO), 1.91 (3H, s, CH₃CO), 1.89 (6H, s, CH₃CO), 1.76 (3H, s, CH₃CONH), 1.65 (1H, t, $J = 12.6$ Hz, 1H, H-3ax NeuAc), 0.97 (9H, s, *tert*-butyl), 0.92 (3H, d, $J = 6.5$ Hz, H-6 Fuc); ¹³C NMR (62.5 MHz, CDCl₃) δ 170.5, 170.3, 170.1, 169.9, 169.5, 167.3, 144.4, 139.2, 138.8, 138.7, 138.0, 135.6, 135.6, 134.9, 134.0, 133.6, 129.6, 129.5, 128.9, 128.6, 128.3, 128.2, 127.9, 127.6, 127.4, 127.2, 127.1, 100.0, 97.4, 97.2, 95.2, 79.5, 77.9, 76.1, 74.6, 73.8, 73.4, 73.2, 72.3, 71.9, 70.2, 69.4, 68.6, 68.4, 68.2, 68.0, 67.2, 66.7, 62.2, 62.1, 49.3, 37.6, 26.9, 23.1, 21.3, 20.8, 20.7, 19.3, 16.6; HRMS (FAB) calcd for ¹²C₉₂H₁₀₇NNaO₂₇Si 1708.6697, found 1708.6827.

[(Benzyl 5-acetamido-4,7,8,9-tetra-*O*-acetyl-3,5-dideoxy-*O*-glycero- α -D-galacto-2-nonulopyranosylate)-(2 \rightarrow 3)]-(2,4-di-*O*-acetyl-6-*O*-benzyl- β -D-galactopyranosyl)-(1 \rightarrow 4)]-[(4-*O*-benzoyl-6-deoxy-2,3-di-*O*-benzyl- α -L-galactopyranosyl)-(1 \rightarrow 3)]-1,5-anhydro-6-*O*-(*tert*-butyldiphenylsilyl)-2-deoxy-D-*arabino*-hex-1-enopyranose (28). The trisaccharide **25** (585 mg, 0.55 mmol), silver triflate (141 mg, 0.55 mmol), 2,6-di-*tert*-butylpyridine (124 μ L, 0.55 mmol), and calcium sulfate (500 mg) were diluted in 2 mL of THF and stirred at room temperature for 30 min. The reaction mixture was cooled to -78 °C, and sialic acid donor **26** (294 mg, 0.55 mmol) was added dropwise over 1 h. After the addition was complete, the temperature was warmed to -55 °C for 1 h, then again cooled to -78 °C before addition of the second portion of silver triflate (141 mg, 0.55 mmol), 2,6-di-*tert*-butylpyridine (124 μ L, 0.55 mmol), and **26** (294 mg, 0.55

mmol), which was again added dropwise over 1 h. After the addition was complete, the reaction temperature was warmed to -5°C for 1 h, then allowed to slowly warm to -10°C overnight. The reaction was quenched by filtration through Celite, concentration, and flash column chromatography, eluting with 7:3 benzene:acetone to give a mixture of starting trisaccharide, the 2,3-dehydrosialyl derivative, and the desired product, which were subjected to acetylation in dichloromethane with acetic anhydride, pyridine, and catalytic DMAP for 12 h. The reaction mixture was concentrated and subjected to medium-pressure liquid chromatography (LiChroprep Si 60 40–63 mm), eluting with 2:1:0.1 ethyl acetate:hexanes:acetone to afford the tetrasaccharide glycol **28** as a pure white solid in 40% yield, 83% based on recovered starting material: $[\alpha]_{\text{D}}^{25} -33.3^{\circ}$ (*c* 2.25, CHCl_3); IR (neat) 3059, 3033, 2956, 2926, 2860, 1748, 1727, 1717, 1641, 1370, 1263, 1217, 1100, 1069, 1034, 738, 697 cm^{-1} ; $^1\text{H NMR}$ (490 MHz, CDCl_3) δ 7.97 (1H, d, $J = 8.2$ Hz), 7.67 (3H, dd, $J = 6.8, 1.3$ Hz), 7.53 (1H, t, $J = 7.6$ Hz), 7.43–7.18 (29H), 6.27 (1H, d, $J = 6.2$ Hz, H-1 glucal), 5.46 (1H, m, H-8 NeuAc), 5.45 (1H, m), 5.40 (1H, d, $J = 12.2$ Hz, OCHHPH), 5.32 (1H, dd, $J = 8.2, 2.3$ Hz, H-7 NeuAc), 5.22 (1H, d, $J = 3.5$ Hz, H-4 Gal), 5.09 (1H, d, $J = 12.2$ Hz, OCHHPH), 5.00 (1H, dd, $J = 9.7, 8.2$ Hz, H-2 Gal), 4.92 (1H, d, $J = 3.5$ Hz), 4.91–4.85 (3H), 4.77 (1H, m), 4.61 (1H, m), 4.59 (1H, d, $J = 11.1$ Hz, OCHHPH), 4.52 (1H, d, $J = 12.3$ Hz, OCHHPH), 4.48 (1H, d, $J = 12.3$ Hz, OCHHPH), 4.41 (1H, d, $J = 11.8$ Hz, OCHHPH), 4.34 (1H, d, $J = 11.1$ Hz, OCHHPH), 4.28 (1H, dd, $J = 12.6, 2.4$ Hz), 4.25 (1H, m), 4.19 (1H, d, $J = 6.9$ Hz), 4.14 (1H, m), 4.12 (1H, m), 4.06 (1H, m), 4.01–3.96 (3H), 3.88–3.83 (2H, m), 3.78 (1H, dd, $J = 9.9, 3.4$ Hz), 3.54 (1H, dd, $J = 9.9, 4.1$ Hz), 3.48 (1H, dd, $J = 10.8, 2.2$ Hz), 3.42 (1H, m), 2.59 (1H, dd, $J = 12.5, 4.9$ Hz, H-3eq NeuAc), 2.13 (3H, s, CH_3CO), 2.10 (3H, s, CH_3CO), 2.09 (3H, s, CH_3CO), 2.06 (3H, s, CH_3CO), 2.03 (3H, s, CH_3CO), 1.97 (3H, s, CH_3CO), 1.82 (3H, s, CH_3CONH), 1.71 (1H, t, $J = 12.5$ Hz, H-3ax NeuAc), 1.06 (1H, d, $J = 5.6$ Hz, H-6 Fuc), 1.05 (9H, s, *tert*-butyl); $^{13}\text{C NMR}$ (62.5 MHz, CDCl_3) δ 170.5, 170.4, 170.2, 170.1, 169.4, 167.3, 166.2, 144.6, 138.6, 138.4, 137.9, 135.7, 135.6, 134.9, 133.9, 133.6, 132.9, 130.1, 129.8, 129.6, 128.9, 128.6, 128.3, 128.2, 128.1, 120.0, 127.7, 127.6, 127.5, 99.8, 97.4, 97.1, 97.0, 95.1, 77.3, 74.6, 73.3, 73.0, 72.8, 72.4, 71.8, 71.8, 71.6, 70.3, 69.4, 68.6, 68.4, 68.0, 67.8, 67.1, 65.1, 62.2, 61.9, 49.1, 37.6, 30.9, 29.7, 29.3, 26.9, 23.2, 21.3, 20.8, 20.7, 20.6, 19.3, 16.2; HRMS (FAB) calcd for $^{13}\text{C}_{12}\text{H}_{105}\text{NNaO}_{28}\text{Si}$ 1723.6523, found 1723.6687.

O-[(5-Acetamido-4,7,8,9-tetra-O-acetyl-3,5-dideoxy-D-glycero- α -D-galacto-2-nonulopyranosylonic acid)-(2 \rightarrow 3)-O-(2,4,6-tri-O-acetyl- β -D-galactopyranosyl)-(1 \rightarrow 4)]-O-[(6-deoxy-2,3,4-tri-O-acetyl- α -L-galactopyranosyl)-(1 \rightarrow 3)]-6-O-acetyl-1,5-anhydro-2-deoxy-D-arabino-hex-1-enopyranose-(1 \rightarrow 2)-lactone (29). Tetrabutyl ammonium fluoride (TBAF) (150 mL, 1 M in THF) was added to sLe^x glycol **27** (38 mg, 22.4 mmol) in 0.5 mL of THF. The mixture was stirred overnight at room temperature, then concentrated. To the residue was added 1 mL of 2% NaOMe in MeOH, and the mixture was stirred at room temperature for 1 day. To this were added 1 mL of water and 1 mL of THF, and the mixture was stirred an additional 24 h at room temperature. The reaction mixture was cooled to 0°C , and the pH was adjusted to 8–9 with ion-exchange resin (Dowex 50 \times 8-400). The resin was removed by filtration, and the filtrate was concentrated to dryness. To the residue was added 2 mL of dry THF, 15 mL of liquid NH_3 , and then Na (ca. $4 \times 4 \times 4$ mm) at -78°C . The deeply blue-colored solution was stirred under reflux of NH_3 for 15 min. The reaction was quenched with 5 mL of MeOH, and the NH_3 was evaporated. The residual mixture was treated with ion-exchange resin (Dowex 50 \times 8-400) to pH 10 and concentrated *in vacuo*. To the residue were added 2 mL of pyridine and 2 mL of acetic anhydride, and the mixture was stirred overnight at room temperature. The mixture was concentrated *in vacuo*, and the residue was subjected to flash column chromatography using benzene:acetone 90:10 ~ 70:30 or column chromatography using LH20 with MeOH to afford **29**. Further purification was performed on HPLC (Econosil 5 mm, 4.6 mm i.d. \times 250 mm, benzene:acetone 7:3, 1 mL/min): 78% yield as a colorless solid; $[\alpha]_{\text{D}}^{25} -104^{\circ}$ (*c* 0.75, CHCl_3); FTIR (neat) 2948, 2924, 1742, 1688, 1354, 1218, 1048, 1028 cm^{-1} ; $^1\text{H NMR}$ (490 MHz, CDCl_3) δ 6.45 (1H, d, $J = 6.4$ Hz, H-1 glucal), 5.49 (1H, dd, $J = 3.0, 1.0$ Hz, H-4 Gal), 5.44 (1H, ddd, $J = 11.0, 11.0, 5.5$ Hz, H-4 NeuAc), 5.15 (1H, d, $J = 11.0, 4.0, 1.0$ Hz, H-2 or H-3 Fuc), 5.01 (1H, app quintet,

$J = 4.0$ Hz, H-8 NeuAc), 5.37–5.27 (5H), 4.92 (1H, dd, $J = 6.5, 4.0$ Hz, H-2 glucal), 4.75 (1H, d, $J = 7.5$ Hz, H-1 Gal), 4.69 (1H, dd, $J = 10.5, 7.5$ Hz, H-2 Gal), 4.43–4.27 (6H, including H-3 Gln, H-9 NeuAc, H-5 Fuc), 4.20–4.12 (3H), 4.05–3.98 (4H, including H-9 NeuAc), 3.74 (1H, dd, $J = 10.5, 1.9$ Hz, H-6 NeuAc), 2.47 (1H, dd, $J = 10.5, 5.0$ Hz, H-3eq NeuAc), 1.92 (1H, t, $J = 10.5$ Hz, H-3ax NeuAc), 2.21 (3H, s, CH_3CO), 2.16 (3H, s, CH_3CO), 2.12 (3H, s, CH_3CO), 2.09 (3H, s, CH_3CO), 2.08 (3H, s, CH_3CO), 2.07 (3H, s, CH_3CO), 2.06 (3H, s, CH_3CO), 2.04 (3H, s, CH_3CO), 2.02 (3H, s, CH_3CO), 1.98 (3H, s, CH_3CO), 1.89 (3H, s, CH_3CO), 1.16 (3H, d, $J = 6.5$ Hz, H-6 Fuc); $^{13}\text{C NMR}$ (62.5 MHz, CDCl_3) δ 170.8, 170.4, 170.3, 169.6, 169.5, 169.5, 163.5, 145.4, 99.9, 97.1, 96.9, 92.6, 77.2, 74.8, 74.2, 74.0, 73.5, 72.7, 71.4, 71.3, 69.5, 69.4, 68.1, 68.0, 67.1, 66.1, 65.2, 61.8, 61.1, 49.4, 37.9, 23.1, 20.8, 20.6, 20.6, 20.5, 20.4, 15.9; HRMS (FAB) calcd for $\text{C}_{49}\text{H}_{66}\text{NNaO}_{30}$ 1148.3669, found 1146.3631.

O-[(Sodium 5-acetamido-3,5-dideoxy-D-glycero- α -D-galacto-2-nonulopyranosylate)-(2 \rightarrow 3)-O-(β -D-galactopyranosyl)-(1 \rightarrow 4)]-O-[(6-deoxy- α -L-galactopyranosyl)-(1 \rightarrow 3)]-1,5-anhydro-2-deoxy-D-arabino-hex-1-enopyranose (30). To the sLe^x glycol peracetate **29** (10 mg, 8.7 mmol) were added 2 mL of MeOH and 10 mL of 25% NaOMe. The mixture was stirred overnight at room temperature. To this was then added 1 mL of water, and the mixture was stirred for an additional 24 h at room temperature. The reaction mixture was cooled to 0°C , and the pH was adjusted to 8–9 with ion-exchange resin (Dowex 50X8-400). The resin was removed by filtration and the filtrate concentrated. The residue was subjected to Bio-Gel P2 column chromatography, eluting with water to afford the title compound in quantitative yield as a colorless solid: $[\alpha]_{\text{D}}^{25} -70.3^{\circ}$ (*c* 0.3, H_2O); FTIR (KBr disk) 3347, 2930, 1690, 1070, 1025 cm^{-1} ; $^1\text{H NMR}$ (490 MHz, D_2O , HDO) δ 6.51 (1H, d, $J = 6.0$ Hz, H-1 glucal), 5.06 (1H, d, $J = 4.5$ Hz, H-1 Fuc), 5.01 (1H, dd, $J = 6.0, 3.0$ Hz, H-2 glucal), 4.63 (1H, d, $J = 8.0$ Hz, H-1 Gal), 4.47 (1H, q, $J = 7.0$ Hz, H-5 Fuc), 4.33 (1H, br s), 4.18 (1H, br d, $J = 3.0$ Hz), 4.10 (1H, dd, $J = 10.5, 3.0$ Hz), 4.02–3.95 (2H), 3.95–3.85 (5H), 3.85–3.77 (2H), 3.75–3.68 (3H), 3.68–3.63 (3H), 3.60 (1H, br d, $J = 9.0$ Hz), 3.55 (1H, dd, $J = 9.0, 7.5$ Hz), 2.77 (1H, dd, $J = 12.0, 4.0$ Hz, H-3eq NeuAc), 2.04 (3H, s, CH_3CONH), 1.81 (1H, t, $J = 12.0$ Hz, H-3ax NeuAc), 1.21 (3H, d, $J = 6.5$ Hz, H-6 Fuc); $^{13}\text{C NMR}$ (123 MHz, D_2O) δ 175.3, 174.1, 144.6, 102.1, 100.1, 99.1, 96.3, 77.8, 75.9, 75.2, 73.1, 72.7, 72.1, 72.1, 70.1, 69.7, 68.6, 68.4, 68.0, 67.6, 67.0, 62.9, 61.4, 59.4, 52.0, 40.0, 22.3, 15.5; HRMS (FAB) calcd for $\text{C}_{29}\text{H}_{47}\text{H}_{47}\text{NNaO}_{21}$ 768.2538, found 768.2474.

N-[O-[(Benzyl 5-acetamido-4,7,8,9-tetra-O-acetyl-3,5-dideoxy-D-glycero- α -D-galacto-2-nonulopyranosylate)-(2 \rightarrow 3)-O-(2,4-di-O-acetyl-6-O-benzyl- β -D-galactopyranosyl)-(1 \rightarrow 4)]-O-[6-deoxy-2,3,4-tri-O-benzyl- α -L-galactopyranosyl-(1 \rightarrow 3)]-6-O-(*tert*-butyldiphenylsilyl)-2-deoxy-2-iodo- α -D-manno-pyranosyl]benzenesulfonamide (31). A suspension of Le^x glycol **27** (61.7 mg, 36.3 mmol), benzenesulfonamide (22.8 mg, 145 mmol), and powdered 4 Å molecular sieves (120 mg) in 2 mL of CH_2Cl_2 was stirred at room temperature for 10 min then cooled to 0°C . Then I(*sym*-collidine) $_2\text{ClO}_4$ (68.1 mg, 145 mmol) was added in one portion, and the mixture was stirred at 0°C . When TLC indicated no starting glycol, the mixture was diluted with 5 mL of ethyl acetate and filtered. The filtrate was washed with saturated $\text{Na}_2\text{S}_2\text{O}_3$, saturated CuSO_4 , and saturated NaCl, then dried over (MgSO_4) and concentrated. The residue was subjected to flash column chromatography using benzene:acetone 95:5~85:15 to afford the iodosulfonamide in 92% yield as a colorless glass: $[\alpha]_{\text{D}}^{20} -32.5^{\circ}$ (*c* 0.625, CHCl_3); FTIR (neat) 3000, 2850, 1746, 1366, 1230 cm^{-1} ; $^1\text{H NMR}$ (490 MHz, CDCl_3) δ 7.77 (1H, d, $J = 8.0$ Hz), 7.62 (2H, br t, $J = 8.0$ Hz), 7.44–7.15 (37H), 5.4–5.45 (2H), 5.40 (1H, d, $J = 11.9$ Hz, $\text{PhCH}_2\text{O}-$), 5.36 (1H, dd, $J = 8.9, 2.5$ Hz), 5.27 (1H, br d, $J = 3.0$ Hz), 5.24 (1H, br s), 5.16 (1H, d, $J = 3.4$ Hz), 5.08 (1H, d, $J = 11.8$ Hz, $\text{PhCH}_2\text{O}-$), 4.91 (1H, dd, $J = 10.0, 7.7$ Hz), 4.84–4.90 (4H), 4.67 (1H, d, $J = 7.5$ Hz), 4.64 (1H, d, $J = 11.1$ Hz, $\text{PhCH}_2\text{O}-$), 4.56 (1H, dd, $J = 11.1$ Hz, $\text{PhCH}_2\text{O}-$), 4.55 (2H, m), 4.53 (1H, d, $J = 11.8$ Hz, $\text{PhCH}_2\text{O}-$), 4.32 (1H, d, $J = 11.8$ Hz, $\text{PhCH}_2\text{O}-$), 4.32 (1H, d, $J = 9.6, 2.2$ Hz), 4.18 (1H, br d, $J = 12.0$ Hz), 3.98–4.05 (4H), 3.88 (1H, br s), 3.80 (2H, m), 3.50, 3.40 (2H), 2.58 (1H, dd, $J = 12.0, 4.5$ Hz), 2.11, 2.03, 1.98, 1.96, 1.88, 1.83, 1.58 (7Ac), 1.70 (1H, t, $J = 12.0$ Hz), 1.03 (9H, s), 1.01 (3H, d, $J = 6.0$ Hz); $^{13}\text{C NMR}$ (62.5 MHz, CDCl_3) δ 170.6, 170.4, 170.0, 169.8, 169.2, 167.2, 141.6, 138.9, 138.6, 137.9, 135.5, 134.7,

133.4, 133.0, 132.0, 129.8, 129.7, 128.8, 128.5, 128.4, 128.2, 128.1, 127.9, 127.7, 127.6, 127.5, 127.4, 127.3, 127.1, 127.0, 100.9, 98.4, 97.1, 79.3, 77.2, 76.2, 75.9, 74.5, 73.4, 73.2, 72.4, 71.9, 71.3, 70.4, 69.4, 68.4, 68.2, 68.0, 67.9, 67.1, 66.8, 61.9, 61.7, 48.8, 37.3, 27.3, 27.0, 26.9, 23.1, 21.2, 20.8, 20.6, 20.5, 20.4, 19.1, 16.5; HRMS (FAB) calcd for $^{12}\text{C}_{97}^{13}\text{C}_{113}\text{I}_2\text{N}_2\text{NaO}_{29}\text{SSi}$ ($\text{M} + \text{Na}^+$) 1992.5897, found 1992.6047.

***N*-[*O*-(benzyl 5-acetamido-4,7,8,9-tetra-*O*-acetyl-3,5-dideoxy- α -D-galacto-2-nonulopyranosylonate)-(2 \rightarrow 3)-*O*-(2,4-di-*O*-acetyl-6-*O*-benzyl- β -D-galactopyranosyl)-(1 \rightarrow 4)]-*O*-(6-deoxy-2,3,4-tri-*O*-benzyl- α -L-galactopyranosyl)-(1 \rightarrow 3)]-6-*O*-(*tert*-butyldiphenylsilyl)-2-deoxy-2-iodo- α -D-mannopyranosyl]-2-(trimethylsilyl)ethanesulfonamide (32).** To a suspension of glycal 27 (101 mg, 0.0599 mmol), 2-(trimethylsilyl)ethanesulfonamide (21 mg, 0.12 mmol), and powdered 4 Å molecular sieves (110 mg) in CH_2Cl_2 (2 mL) at 0 °C was added solid $\text{I}(\text{sym-collidine})_2\text{ClO}_4$ (70 mg, 0.15 mmol). Following stirring for 30 min, the mixture was filtered and diluted with ether (30 mL). The organic layer was washed with saturated $\text{Na}_2\text{S}_2\text{O}_3$ (3 mL), saturated CuSO_4 (3 \times 3 mL), and saturated NaCl (3 mL), dried (Na_2SO_4), and concentrated. Chromatography (silica, 25% acetone in toluene) subsequently provided iodosulfonamide 32 (97.7 mg, 82%) as a colorless glass: $[\alpha]_{\text{D}} -39.7^\circ$ (c 0.88, CH_2Cl_2); IR (neat) 3360, 2930, 1745, 1370, 1230, 1110, 1080, 1045 cm^{-1} ; ^1H NMR (490 MHz, CDCl_3) δ 7.70–7.65 (4H, m, *ArH*), 7.47–7.20 (31H, m, *ArH*), 5.47 (1H, ddd, J = 8.6, 4.4, 2.4 Hz, H-8 Neu5Ac), 5.44 (1H, d, J = 12.0 Hz, OCHHPh), 5.39 (1H, dd, J = 8.6, 2.5 Hz, H-7 Neu5Ac), 5.32 (1H, t, J = 9.7 Hz, H-1 Glc), 5.32 (1H, d, J = 4.0 Hz, H-1 Fuc), 5.21 (1H, d, J = 3.4 Hz, H-4 Gal), 5.17 (1H, d, J = 9.4 Hz, *NH* Man), 5.12 (1H, d, J = 12.0 Hz, OCHHPh), 5.01 (1H, dd, J = 10.0, 8.0 Hz, H-2 Gal), 4.96 (1H, d, J = 10.4 Hz, *NH* Neu5Ac), 4.93–4.87 (1H, m, H-4 Neu5Ac), 4.90 (1H, d, J = 11.4 Hz, OCHHPh), 4.88 (1H, d, J = 11.8 Hz, OCHHPh), 4.75 (1H, d, J = 7.9 Hz, H-1 Gal), 4.65 (1H, d, J = 12.3 Hz, OCHHPh), 4.62 (1H, dd, J = 10.1, 3.5 Hz, H-3 Gal), 4.57 (1H, d, J = 11.4 Hz, OCHHPh), 4.55 (1H, d, J = 11.5 Hz, OCHHPh), 4.54 (1H, d, J = 11.4 Hz, OCHHPh), 4.43 (1H, d, J = 11.4 Hz, OCHHPh), 4.43–4.39 (1H, m, H-2 Man), 4.32 (1H, d, J = 11.6 Hz, OCHHPh), 4.29 (1H, dd, J = 12.6, 2.4 Hz, H-9 Neu5Ac), 4.11–3.98 (6H, m), 4.88–4.77 (3H, m), 3.65 (1H, br d, J = 10.2 Hz, H-3 Fuc), 3.56–3.49 (2H, m), 3.46–3.40 (2H, m), 3.33–2.93 (2H, m, $\text{SO}_2\text{CH}_2\text{CH}_2\text{Si}$), 2.64 (1H, dd, J = 12.6, 4.6 Hz, H-3_e Neu5Ac), 2.15 (3H, s, CH_3CO), 2.13 (3H, s, CH_3CO), 2.07 (3H, s, CH_3CO), 2.03 (3H, s, CH_3CO), 2.00 (3H, s, CH_3CO), 1.96 (3H, s, CH_3CO), 1.85 (3H, s, CH_3CO), 1.73 (1H, t, J = 12.3 Hz, H-3_e Neu5Ac), 1.11–1.01 (2H, m, $\text{SO}_2\text{CH}_2\text{CH}_2\text{Si}$), 1.04 (9H, s, $\text{Si}(\text{CH}_3)_3$), 0.97 (3H, d, J = 6.4 Hz, CH_3 Fuc), -0.05 (9H, s, $\text{Si}(\text{CH}_3)_3$); ^{13}C NMR (63 MHz, CDCl_3) δ 170.6, 170.3, 170.2, 169.9, 169.4, 169.3, 167.3, 138.9, 138.6, 137.9, 135.5, 134.8, 133.3, 132.7, 129.9, 129.8, 128.8, 128.6, 128.3, 128.2, 128.1, 127.9, 127.8, 127.6, 127.5, 127.2, 127.1, 101.0, 100.5, 99.2, 97.0, 79.4, 79.3, 77.8, 77.6, 77.3, 76.2, 75.7, 74.5, 73.4, 73.3, 72.4, 71.8, 71.6, 70.4, 69.4, 68.4, 68.3, 67.8, 67.3, 67.0, 62.1, 61.9, 51.2, 49.0, 37.5, 27.8, 26.9, 23.1, 21.3, 20.9, 20.6, 19.1, 16.5, 10.4, -2.0 ; MS (FAB) *m/e* (relative intensity) 2016 ($\text{M} + \text{Na}^+$, 3), 886 (29), 736 (33), 550 (25), 491 (26), 490 (100), 229 (23); HRMS (FAB) calcd for $^{12}\text{C}_{96}^{13}\text{C}_{112}\text{I}_2\text{N}_2\text{O}_{29}\text{SSi}_2$ ($\text{M} + \text{Na}^+$) 2016.6292, found 2016.6518.

***O*-Benzyl-*O*[(benzyl 5-acetamido-4,7,8,9-tetra-*O*-acetyl-3,5-dideoxy- α -D-glycero- α -D-galacto-2-nonulopyranosylonate)-(2 \rightarrow 3)-*O*-(2,4-di-*O*-acetyl-6-*O*-benzyl- β -D-galactopyranosyl)-(1 \rightarrow 4)]-*O*-(6-deoxy-2,3,4-tri-*O*-benzyl- α -L-galactopyranosyl)-(1 \rightarrow 3)]-6-*O*-(*tert*-butyldiphenylsilyl)-2-deoxy-2-iodo-2-(2-(trimethylsilyl)ethanesulfonamido)- β -D-glucopyranose (34).** A solution of iodosulfonamide 32 (98 mg, 0.0491 mmol) in THF (2 mL) at -78 °C was treated with tributyltin benzyloxide (200 mg, 0.50 mmol). Following addition of silver trifluoromethanesulfonate (129 mg, 0.502 mmol) in THF (0.5 mL), the reaction was covered with aluminum foil and allowed to slowly warm to room temperature. After stirring overnight, the reaction was diluted with ether (15 mL) and treated with saturated aqueous KF (3 mL). The reaction mixture was rapidly stirred for an additional 3 h, then filtered through Celite. The aqueous layer was diluted with brine (10 mL) and extracted with ethyl acetate (3 \times 10 mL). The combined organic layers were dried (MgSO_4), concentrated, and chromatographed (silica, 20 \rightarrow 25 \rightarrow 30% acetone in toluene). The product containing residue was dissolved in acetonitrile (10 mL) and washed with hexanes

(6 \times 5 mL) to remove any remaining tin species. Concentration afforded benzyl glycoside 34 (62.2 mg, 64%) as a colorless glass: $[\alpha]_{\text{D}}^{25} -41.1^\circ$ (c 1.27, CH_2Cl_2); IR (neat) 3310, 2920, 1745, 1365, 1230, 1105, 1085, 1065, 1045 cm^{-1} ; ^1H NMR (490 MHz, CDCl_3) δ 7.67–7.62 (2H, m, $\text{SO}_2\text{C}(\text{CH}_2\text{CH}_2)_2\text{CH}$), 7.46–7.21 (38H, m, *ArH*), 5.71 (1H, d, J = 7.9 Hz, *NH* GlcN), 5.54 (1H, ddd, J = 8.9, 5.6, 2.7 Hz, H-8 Neu5Ac), 5.43 (1H, d, J = 12.1 Hz, OCHHPh), 5.42 (1H, d, J = 3.4 Hz, H-1 Fuc), 5.32 (1H, dd, J = 9.0, 2.6 Hz, H-7 Neu5Ac), 5.20 (1H, d, J = 3.4 Hz, H-4 Gal), 5.10 (1H, d, J = 12.1 Hz, OCHHPh), 5.00 (1H, dd, J = 9.9, 7.8 Hz, H-2 Gal), 4.94 (1H, d, J = 11.6 Hz, OCHHPh), 4.90 (1H, d, J = 7.8 Hz, H-1 Gal), 4.88 (1H, d, J = 10.3 Hz, *NH* Neu5Ac), 4.87 (1H, ddd, J = 11.0, 10.4, 4.8 Hz, H-4 Neu5Ac), 4.77 (1H, d, J = 11.1 Hz, OCHHPh), 4.77 (1H, d, J = 11.6 Hz, OCHHPh), 4.76 (1H, d, J = 12.0 Hz, OCHHPh), 4.71 (1H, d, J = 11.1 Hz, OCHHPh), 4.60 (1H, dd, J = 9.9, 3.4 Hz, H-3 Gal), 4.57 (1H, d, J = 11.6 Hz, OCHHPh), 4.56 (1H, d, J = 11.6 Hz, OCHHPh), 4.53 (1H, d, J = 11.9 Hz, OCHHPh), 4.42 (1H, d, J = 12.0 Hz, OCHHPh), 4.41 (1H, d, J = 11.9 Hz, OCHHPh), 4.31 (1H, d, J = 6.8 Hz, H-1 GlcN), 4.30 (1H, dd, J = 12.5, 2.6 Hz, H-9 Neu5Ac), 4.10–4.02 (4H, m, H-3 GlcN, H-4 GlcN, H-5 Neu5Ac, H-2 Fuc), 4.00 (1H, dd, J = 10.5, 5.6 Hz, H-6 GlcN), 3.96 (1H, dd, J = 12.5, 5.6 Hz, H-9 Neu5Ac), 3.92–3.85 (4H, m, H-6 GlcN, H-5 Gal, H-3 Fuc, H-5 Fuc), 3.69 (1H, q, J = 5.0 Hz, H-5 GlcN), 3.63 (1H, q, J = 7.3 Hz, H-2 GlcN), 3.61 (1H, dd, J = 9.4, 5.4 Hz, H-6 Gal), 3.51 (1H, dd, J = 10.9, 2.6 Hz, H-6 Neu5Ac), 3.50 (1H, d, J = 2.6 Hz, H-4 Fuc), 3.47 (1H, dd, J = 9.4, 8.0 Hz, H-6 Gal), 2.87 (1H, td, J = 13.4, 5.1 Hz, $\text{SO}_2\text{CHHCH}_2\text{Si}$), 2.80 (1H, td, J = 13.4, 5.3 Hz, $\text{SO}_2\text{CHHCH}_2\text{Si}$), 2.61 (1H, dd, J = 12.7, 4.6 Hz, H-3_e Neu5Ac), 2.10 (3H, s, COCH_3), 2.05 (3H, s, COCH_3), 2.04 (3H, s, COCH_3), 2.02 (3H, s, COCH_3), 2.00 (3H, s, COCH_3), 1.97 (3H, s, COCH_3), 1.84 (3H, s, COCH_3), 1.71 (1H, t, J = 12.4 Hz, H-3_a Neu5Ac), 1.11 (3H, d, J = 6.4 Hz, CH_3 Fuc), 1.06 (9H, s, $\text{Si}(\text{CH}_3)_3$), 0.96–0.82 (2H, m, $\text{SO}_2\text{CH}_2\text{CH}_2\text{Si}$), -0.14 (9H, s, $\text{Si}(\text{CH}_3)_3$); ^{13}C NMR (63 MHz, CDCl_3) δ 170.5, 170.4, 170.2, 170.1, 170.0, 169.9, 167.2, 139.3, 138.9, 138.4, 138.2, 137.4, 135.6, 134.9, 133.5, 133.5, 129.7, 128.8, 128.6, 128.2, 128.1, 127.6, 127.6, 127.4, 127.2, 101.0, 99.6, 97.6, 97.0, 79.4, 78.6, 77.4, 77.3, 75.2, 74.6, 73.4, 73.3, 72.6, 72.2, 72.0, 71.7, 71.3, 69.9, 69.3, 68.4, 67.9, 67.7, 67.6, 67.3, 67.1, 63.9, 62.3, 56.9, 50.2, 49.1, 37.6, 26.9, 23.1, 21.2, 20.9, 20.7, 19.2, 16.8, 10.1, -2.1 ; MS (FAB) *m/e* (relative intensity) 1996 ($\text{M} + \text{Na}^+$, 3), 886 (29), 736 (35), 550 (26), 491 (27), 491 (100), 268 (20), 229 (31); HRMS (FAB) calcd for $^{12}\text{C}_{103}^{13}\text{C}_{118}\text{N}_2\text{O}_{30}\text{SSi}_2$ ($\text{M} + \text{Na}^+$) 1996.7742, found 1996.7918.

Sialyl Lewis X Antigen (1). A suspension of benzyl glycoside 34 (62 mg, 0.31 mmol) and CsF (168 mg, 1.1 mmol) in DMF (1 mL) was heated to 95 °C while stirring rapidly. After 48 h, the reaction was cooled and treated with pyridine (0.5 mL) and acetic anhydride (0.2 mL). Following stirring for an additional 4 h, the reaction was concentrated under reduced pressure, extracted from saturated aqueous sodium bicarbonate (10 mL) with ethyl acetate (3 \times 5 mL), dried (MgSO_4), concentrated, and chromatographed (silica, 20 \rightarrow 30 \rightarrow 40 \rightarrow 50% acetone in toluene) to afford a fraction containing compounds with the sulfonamide still present (7.1 mg) and a fraction containing the desired *N*-acetyl compounds (10.8 mg, ca. 5:1 mixture of benzyl ester:lactone). The sulfonamide containing fractions were resubjected to the deprotection conditions described, providing an additional 1.7 mg of the desired *N*-acetyl compounds.

A solution of the *N*-acetyl fractions in dioxane/methanol/3 M aqueous lithium hydroxide (2.5 mL, 2:2:1) was stirred for 2 days and then neutralized with ion-exchange resin (Dowex 50 \times 8–400), filtered, and concentrated to provide deacetylated material.

A solution of the deacetylated residue in methanol (1.5 mL) was hydrogenated at ambient pressure with 20% Pd(OH)₂ on carbon as a catalyst. After stirring for 3 days, the suspension was filtered through Celite, concentrated, and chromatographed (bio-gel P-2, water) to afford SLe^x (1) (colorless solid, 5.7 mg, 22%) as a 2:1 (α : β) mixture of anomers: $[\alpha]_{\text{D}}^{25} -22^\circ$ (c 0.56, CH_3OH); IR (KBr) 3400 (br), 1625, 1610, 1400, 1380, 1080, 1040 cm^{-1} ; ^1H NMR (500 MHz, D_2O) δ 5.09–5.06 (1 $\frac{2}{3}$ H, m, H-1 GlcNAc α -anomer, H-1 Fuc), 4.80 (1H, q, J = 6.7 Hz, H-5 Fuc), 4.69 (1 $\frac{1}{3}$ H, d, J = 8.0, H-1 GlcNAc β -anomer), 4.50 (2 $\frac{1}{3}$ H, d, J = 7.8 Hz, H-1 Gal α -anomer), 4.49 (1 $\frac{1}{3}$ H, d, J = 7.8 Hz, H-1 Gal β -anomer), 4.12 (2 $\frac{1}{3}$ H, dd, J = 9.9, 3.5 Hz, H-2 GlcNAc α -anomer), 4.06 (2 $\frac{1}{3}$ H, dd, J = 9.8, 3.0 Hz, H-3 Gal α -anomer), 4.05

($^{1/3}$ H, dd, $J = 9.8$, 2.8 Hz, H-3 Gal β -anomer), 4.00–3.79 ($^{10/3}$ H, m), 3.75 (1H, d, $J = 3.2$ Hz, H-4, Fuc), 3.69–3.53 (8H, m), 3.51 ($^{2/3}$ H, dd, $J = 9.8$, 7.8 Hz, H-2 Gal α -anomer), 3.50 ($^{1/3}$ H, dd, $J = 9.8$, 7.8 Hz, H-2 Gal β -anomer), 2.73 (1H, dd, $J = 12.4$, 4.6 Hz, H-3_{eq} Neu5Ac), 2.00 (6H, s, COCH₃), 1.77 (1H, t, $J = 12.2$ Hz, H-3_{ax} Neu5Ac), 1.14 (2H, d, $J = 6.6$ Hz, CH₃ Fuc α -anomer), 1.14 (1H, d, $J = 6.6$ Hz, CH₃ Fuc β -anomer); 13 C NMR (123 MHz, D₂O) δ 175.3, 174.7, 174.5, 174.1, 101.9, 99.9, 98.8, 95.0, 91.4, 75.9, 75.6, 75.2, 73.6, 73.2, 73.0, 72.2, 72.1, 71.5, 69.5, 69.5, 68.6, 68.4, 68.0, 67.6, 66.9, 62.9, 61.8, 60.0, 59.9, 57.2, 54.4, 52.0, 40.0, 22.5, 22.3, 15.5; HRMS (FAB) calcd for C₃₁H₃₃N₂O₂₃ (M + H) 821.3038, found 821.3086.

O-[[Benzyl 5-acetamido-4,7,8,9-tetra-O-acetyl-3,5-dideoxy-D-glycero- α -D-galacto-2-nonulopyranosylonate)-(2 \rightarrow 3)-O-(2,4-di-O-acetyl-6-O-benzyl- β -D-galactopyranosyl)-(1 \rightarrow 4)]-O-[[6-deoxy-2,3,4-tri-O-benzyl- α -L-galactopyranosyl)-(1 \rightarrow 3)]-O-(6-O-(tert-butylidiphenylsilyl)-2-deoxy-2-benzenesulfonamido- β -D-glucopyranosyl)-(1 \rightarrow 3)]-1,5-anhydro-6-O-(tert-butylidiphenylsilyl)-2-deoxy-D-lyxo-hex-1-enopyranose (38). A solution of 6-TBDPS galactal (200 mg, 373 mmol) and bis(tributyltin) oxide (111 mg, 186 mmol) in 20 mL of benzene was heated to reflux and was subjected to azeotropic dehydration using 4 Å molecular sieves overnight. The benzene solution was concentrated *in vacuo*. The resulting stannyl ether was dissolved in 880 mL of dry THF. To a mixture of iodobenzenesulfonamide **31** (19.8 mg, 10.1 mmol) and powdered 4 Å molecular sieves (55 mg) was added 200 mL of stannyl ether THF solution, and the mixture was stirred for 10 min at room temperature. The mixture was cooled to -78 °C, and silver tetrafluoroborate (15.6 mg, 80.4 mmol) in dry THF (200 mL) was added to the mixture. The reaction mixture was allowed to slowly warm to room temperature and stirred until TLC (benzene:acetone, 7:3) indicated no iodobenzenesulfonamide (1 day for galactal and 3 days for lactal). The reaction mixture was quenched by addition of powdered NaHCO₃, and the mixture was filtered. The filtrate was concentrated, and the residue was dissolved in 10 mL of CH₃CN. The CH₃CN solution was washed twice with hexane, and the CH₃CN layer was concentrated. The residue was subjected to flash column chromatography using benzene:acetone (93:7~85:15) to afford the oligosaccharide. **38**: 52% yield as a colorless glass; $[\alpha]_D^{20} -34.6^\circ$ (c 0.58, CHCl₃); FTIR (neat), 2930, 2857, 1750, 1228, 1105, 1043 cm⁻¹; 1 H NMR (490 MHz, CDCl₃) δ 7.77 (1H, d, $J = 7.5$ Hz), 7.62 (2H, dd, $J = 10.5$, 7.5 Hz), 7.53 (2H), 7.46–7.17 (45H), 6.24 (1H, d, $J = 6.0$ Hz, galactal-1), 5.96 (1H, d, $J = 9.5$ Hz, PhSO₂NH), 5.54 (1H, ddd, $J = 9.0$, 5.0, 2.5 Hz), 5.43 (1H, d, $J = 12.0$ Hz, PhCH₂O-), 5.35 (1H, dd, $J = 9.0$, 2.5 Hz), 5.21 (1H, d, $J = 3.5$ Hz), 5.10 (1H, d, $J = 12.5$ Hz), 5.05 (1H, dd, $J = 10.0$, 8.0 Hz), 4.92–4.84 (4H), 4.82 (1H, d, $J = 3.5$ Hz), 4.78 (1H, d, $J = 7.5$ Hz), 4.68 (1H, d, $J = 12.0$ Hz), 4.65 (1H, dd, $J = 10.0$, 3.5 Hz), 4.59 (1H, d, $J = 12.0$ Hz), 4.56 (2H), 4.54 (1H, br d, $J = 1.8$ Hz), 4.51 (1H, d, $J = 11.5$ Hz), 4.41 (1H, d, $J = 12.0$ Hz), 4.33 (1H, d, $J = 11.0$ Hz), 4.30 (1H, dd, $J = 12.5$, 2.5 Hz), 4.14 (1H, m), 4.16–4.06 (2H), 4.05 (1H, d, $J = 10.5$ Hz), 4.06–4.00 (2H), 3.99–3.93 (2H), 3.90–3.83 (3H), 3.80–3.74 (3H), 3.69 (1H, br s), 3.66 (1H, q, $J = 6.5$ Hz), 3.59 (1H, br s), 3.56 (1H, dd, $J = 9.5$, 5.0 Hz), 3.52 (1H, dd, $J = 11.0$, 3.0 Hz), 3.48 (1H, dd, $J = 10.0$, 2.5 Hz), 3.44 (1H, dd, $J = 9.0$, 8.0 Hz), 3.33 (1H, br d, $J = 2.0$ Hz), 3.07 (1H, br s), 2.62 (1H, dd, $J = 13.0$, 5.0 Hz), 2.14, 2.15, 2.08, 2.05, 1.99, 1.93, 1.84 (7Ac), 1.71 (1H, t, $J = 13.0$ Hz); 13 C NMR (62.5 MHz, CDCl₃) δ 170.9, 170.7, 170.5, 170.5, 169.8, 145.2, 139.4, 139.7, 135.9, 135.7, 135.3, 134.0, 133.8, 132.5, 130.3, 129.9, 129.3, 129.2, 129.0, 128.6, 128.6, 128.5, 128.1, 128.1, 128.0, 127.7, 127.6, 127.4, 100.0, 98.5, 97.4, 80.0, 76.2, 75.1, 73.9, 73.7, 73.6, 72.7, 72.4, 71.7, 71.2, 69.7, 68.9, 68.4, 68.0, 68.0, 67.5, 64.5, 64.3, 62.6, 49.6, 38.0, 30.0, 27.2, 23.5, 21.7, 21.2, 21.1, 19.5, 17.0; HRMS (FAB) calcd for $^{12}C_{119}^{13}CH_{140}N_2NaO_{33}SSi_2$ (M + Na⁺) 2248.8528, found 2248.8764.

O-[[[Benzyl 5-acetamido-4,7,8,9-tetra-O-acetyl-3,5-dideoxy-D-glycero- α -D-galacto-2-nonulopyranosylonate)-(2 \rightarrow 3)-O-(2,4-di-O-acetyl-6-O-benzyl- β -D-galactopyranosyl)-(1 \rightarrow 4)]-O-[[6-deoxy-2,3,4-tri-O-benzyl- α -L-galactopyranosyl)-(1 \rightarrow 3)]-O-(6-O-(tert-butylidiphenylsilyl)-2-deoxy-2-benzenesulfonamido- β -D-glucopyranosyl)-(1 \rightarrow 3)]-O-(6-O-(tert-butylidimethylsilyl)- β -D-galactopyranosyl)-(1 \rightarrow 4)]-1,5-anhydro-6-O-(tert-butylidimethylsilyl)-2-deoxy-D-arabino-hex-1-enopyranose (39): 43% yield as a colorless glass; $[\alpha]_D^{20} -14.4^\circ$ (c 0.55, CHCl₃); FTIR (neat) 3476, 2926, 2850, 1745, 1366, 1214, 1087, 1043 cm⁻¹; 1 H NMR (500 MHz, CDCl₃) δ 7.80 (1H, d, $J = 8.0$ Hz),

7.57 (2H, t, $J = 8.0$ Hz), 7.46–7.20 (37H), 6.30 (1H, dd, $J = 6.0$, 1.7 Hz, glugal-1), 6.08 (1H, d, $J = 9.3$ Hz, NHSO₂Ph), 5.55 (1H, ddd, $J = 8.6$, 5.4, 2.6 Hz, NeuAc-8), 5.44 (1H, d, $J = 12$ Hz, PhCH₂O-), 5.34 (1H, dd, $J = 8.9$, 2.6 Hz, NeuAc-7), 5.15 (1H, d, $J = 3.4$ Hz, Gal'''-4), 5.10 (1H, d, $J = 12$ Hz, PhCH₂O-), 5.07 (1H, dd, $J = 10.1$, 7.8 Hz, Gal'''-2), 4.92 (1H, d, $J = 10.0$ Hz, NeuAc-5-NH), 4.91 (1H, d, $J = 5.4$ Hz, GlcN-1), 4.88 (1H, d, $J = 11.5$ Hz, PhCH₂O-), 4.88 (1H, NeuAc-4), 4.77 (1H, d, $J = 8.8$ Hz, Gal'''-1), 4.69 (1H, d, $J = 6.0$, 2.0 Hz, glugal-2), 4.65 (1H, dd, $J = 10.2$, 3.4 Hz, Gal'''-3), 4.59 (1H, d, $J = 11.9$ Hz, PhCH₂O-), 4.56 (1H, d, $J = 2.0$ Hz, Fuc-1), 4.55 (1H, d, $J = 11.3$ Hz, PhCH₂O-), 4.53 (1H, d, $J = 10.2$ Hz, PhCH₂O-), 4.50 (1H, d, $J = 11.8$ Hz, PhCH₂O-), 4.47 (1H, d, $J = 12.4$ Hz, PhCH₂O-), 4.44 (1H, d, $J = 12.1$ Hz, PhCH₂O-), 4.40 (1H, br d, $J = 7.1$ Hz, glugal-3), 4.35 (1H, NeuAc-9), 4.34 (1H, d, $J = 7.3$ Hz, Gal'-1), 4.34 (1H, d, $J = 11.3$ Hz, PhCH₂O-), 4.26 (1H, br s, glugal-3-OH), 4.09–3.97 (4H, NeuAc-5, glugal-6,6', GlcN-3), 3.95–3.78 (7H, NeuAc-9, GlcN-4, Gal'''-5, GlcN-5, Glugal-5, Gal'-4, Fuc-2), 3.65 (1H, dd, $J = 10.2$, 4.4 Hz, GlcN-6), 3.65 (1H, dd, $J = 10.2$, 7.4 Hz, Glugal-4), 3.60–3.50 (6H, Gal'-2, Gal'''-6, Gal'-3, GlcN-2, Fuc-5, NeuAc-6), 3.45 (1H, GlcN-6), 3.43 (1H, dd, $J = 9.6$, 7.2 Hz, Gal'''-6), 3.38 (1H, br d, $J = 10.2$ Hz, Fuc-3), 3.30 (1H, Br s, Fuc-2), 3.22 (1H, Gal'-4-OH), 3.18 (1H, Gal'-2-OH), 2.61 (1H, dd, $J = 12.7$, 4.7 Hz, NeuAc-3eq), 2.14, 2.13, 2.10, 2.05, 2.00, 1.94, 1.84 (17Ac), 1.71 (1H, t, $J = 12.7$ Hz, NeuAc-3ax), 1.03, 0.91, 0.82 (3'Bu-), 0.97 (3H, d, $J = 6.5$ Hz, Fuc-6), 0.12, 0.10, 0.00, -0.02 (3H, s, MeSi-); 13 C NMR (123 MHz, CDCl₃) δ 170.5, 170.4, 170.3, 170.2, 169.5, 167.3, 143.7, 138.8, 137.9, 137.9, 135.5, 135.4, 134.8, 133.3, 132.9, 132.2, 130.0, 128.9, 128.9, 128.8, 128.6, 128.5, 128.4, 128.3, 128.2, 128.0, 127.9, 127.8, 127.8, 127.7, 127.5, 127.4, 127.2, 103.9, 102.5, 102.1, 99.9, 97.8, 97.0, 81.8, 80.6, 79.6, 77.6, 77.5, 77.1, 76.9, 76.4, 75.6, 75.2, 74.7, 73.8, 73.2, 73.2, 72.2, 72.0, 71.2, 70.8, 70.6, 69.2, 68.5, 68.2, 67.9, 67.8, 67.6, 67.5, 67.1, 67.0, 64.1, 62.5, 62.4, 62.3, 55.1, 49.0, 37.6, 29.7, 26.9, 26.0, 25.9, 23.2, 21.4, 20.8, 20.8, 19.1, 16.7, -5.0, -5.1, -5.5, -5.6; HRMS (FAB) calcd for $^{12}C_{120}^{13}C_{121}H_{160}N_2NaO_{38}SSi_3$ 2401.9642 (M + Na⁺), found 2401.9890.

O-[[[5-Acetamido-4,7,8,9-tetra-O-acetyl-3,5-dideoxy-D-glycero- α -D-galacto-2-nonulopyranosylonate)-(2 \rightarrow 3)-O-(2,4,6-tri-O-acetyl- β -D-galactopyranosyl)-(1 \rightarrow 4)]-O-[[6-deoxy-2,3,4-tri-O-acetyl- α -L-galactopyranosyl)-(1 \rightarrow 3)]-O-(6-O-(acetyl-2-acetamido-2-deoxy- β -D-glucopyranosyl)-(1 \rightarrow 3)]-O-(2,4,6-tri-O-acetyl- β -D-galactopyranosyl)-(1 \rightarrow 4)]-1,5-anhydro-3,6-di-O-acetyl-2-deoxy-D-arabino-hex-1-enopyranose-(1''' \rightarrow 2''')-lactone (40). Tetrabutylammonium fluoride (TBAF) (150 mL, 1 M in THF) was added to sialyl glycal **39** (38 mg, 22.4 mmol) in 0.5 mL of THF. The mixture was stirred for 3 h to overnight at room temperature and concentrated. To the residue was added 1 mL of 2% NaOMe in MeOH, and the mixture was stirred at room temperature for 1 day. To this were added 1 mL of water and 1 mL of THF, and the resulting mixture was stirred an additional 1–2 days at room temperature. The reaction mixture was cooled to 0 °C, and the pH was adjusted to 8~9 with ion-exchange resin (Dowex 50 \times 8-400). The resin was removed by filtration, and the filtrate was concentrated to dryness. To the residue were added 2 mL of dry THF, 15 mL of liquid NH₃, and then Na (ca. 4 \times 4 \times 4 mm) at -78 °C. The deeply blue-colored solution was stirred under reflux of NH₃ for 15 min. The reaction was quenched by addition of 5 mL of MeOH, and the NH₃ was evaporated. The residual mixture was treated with ion-exchange resin (Dowex 50 \times 8-400) to pH 10 and concentrated *in vacuo*. To the residue were added 2 mL of pyridine and 2 mL of acetic anhydride, and the mixture was stirred overnight at room temperature. The mixture was concentrated *in vacuo*, and the residue was subjected to flash column chromatography using benzene:acetone (90:10~70:30) or column chromatography using LH20 with MeOH to afford oligosaccharide glycol acetate **40**. Further purification was performed on HPLC (Econosil 5 mm, 4.6 mm i.d. \times 250 mm, benzene:acetone (7:3), 1 mL/min). **40**: 73% yield as a colorless solid; $[\alpha]_D^{20} -47^\circ$ (c 0.4, CHCl₃); FTIR (neat) 2927, 1741, 1368, 1216, 1065 cm⁻¹; 1 H NMR (500 MHz, CDCl₃) δ 6.40 (1H, d, $J = 6.0$ Hz, glugal-1), 5.48 (1H, br d, $J = 3.0$ Hz, Gal'-4), 5.40 (1H, d, $J = 4.1$ Hz, Fuc-1), 5.40 (1H, ddd, $J = 10.5$, 10.5, 6.0 Hz, NeuAc-4), 5.38 (1H, glugal-3), 5.38 (1H, br d, $J = 2.7$ Hz, Gal'''-4), 5.35 (1H, dd, $J = 9.7$, 1.8 Hz, NeuAc-7), 5.30 (1H, d, $J = 10.0$ Hz, NeuAc-5-NH), 5.29 (1H, Fuc-4), 5.26 (1H, dd, $J = 10.5$, 3.5 Hz, Fuc-3), 5.09 (1H, dd, $J = 10.0$, 8.0 Hz, Gal'''-2), 5.06

(1H, dd, $J = 10.5, 4.0$ Hz, Fuc-2), 4.99 (1H, d, $J = 6.5$ Hz, GlcNAc-1), 4.93 (1H, ddd, $J = 9.6, 3.4, 3.4$ Hz, NeuAc-8), 4.84 (1H, dd, $J = 6.1, 3.4$ Hz, glucal-2), 4.83 (1H, dd, $J = 12.0, 3.0$ Hz, GlcNAc-6), 4.72 (1H, m, Fuc-5), 4.64 (1H, d, $J = 7.8$ Hz, Gal'-1), 4.57 (1H, d, $J = 8.0$ Hz, Gal'''-1), 4.53 (1H, dd, $J = 10.5, 7.7$ Hz, Gal'-2), 4.42 (1H, dd, $J = 11.7, 2.6$ Hz, glucal-6), 4.35 (1H, t, $J = 7.5$ Hz, GlcNAc-3), 4.35 (1H, dd, $J = 8.3, 5.6$ Hz, Gal'-6), 4.28 (1H, dd, $J = 12.4, 3.7$ Hz, GlcNAc-6), 4.24 (1H, dd, $J = 12.6, 3.0$ Hz, NeuAc-9), 4.21 (1H, dd, $J = 11.0, 6.4$ Hz, glucal-6), 4.17 (1H, dd, $J = 10.0, 6.8$ Hz, Gal'-6), 4.16 (1H, glucal-5), 4.11 (1H, NeuAc-5), 4.09 (2H, Gal'''-6), 4.10 (1H, dd, $J = 13.0, 4.0$ Hz, NeuAc-9), 3.96 (1H, t, $J = 6.3$ Hz, glucal-4), 3.95 (1H, dd, $J = 10.3, 3.0$ Hz, Gal'-3), 3.93 (1H, Gal'-5), 3.85 (1H, Gal'''-5), 3.85 (1H, dd, $J = 8.5, 7.5$ Hz, GlcNAc-4), 3.81 (1H, dd, $J = 10.0, 3.5$ Hz, Gal'''-3), 3.74 (1H, dd, $J = 10.5, 1.7$ Hz, NeuAc-6), 3.65 (1H, ddd, $J = 8.3, 3.7, 3.7$ Hz, Gln-5), 3.33 (1H, q, $J = 6.0$ Hz, Gln-2), 2.50 (1H, dd, $J = 13.5, 5.0$ Hz, NeuAc-3eq), 1.92 (1H, t, $J = 13.5$ Hz, NeuAc-3ax), 2.20, 2.16, 2.15, 2.14, 2.13, 2.12, 2.10, 2.09, 2.09, 2.09, 2.08, 2.08, 2.02 \times 2, 1.98, 1.93, 1.91 (17 Ac), 1.15 (3H, d, $J = 6.5$ Hz, Fuc-6); ^{13}C NMR (123 MHz, CDCl_3) δ 170.9, 170.7, 170.6, 170.5, 170.4, 170.0, 169.6, 145.4, 100.7, 100.3, 99.4, 98.9, 95.2, 76.6, 75.7, 74.3, 74.2, 73.9, 73.5, 73.2, 72.1, 71.3, 71.1, 70.8, 69.5, 69.1, 68.6, 67.8, 66.3, 65.6, 64.6, 61.9, 61.8, 61.3, 60.6, 37.8, 23.3, 23.2, 21.1, 21.0, 20.9, 20.8, 20.8, 20.7, 20.4, 15.8; HRMS (FAB) calcd for $\text{C}_{73}\text{H}_{98}\text{N}_2\text{NaO}_{45}$ 1745.5339 ($\text{M} + \text{Na}^+$), found 1745.5442.

1,5-Anhydro-6-*O*-(*tert*-butyldimethylsilyl)-2-deoxy-D-arabino-hex-1-enopyranose (44). *tert*-Butyldimethylsilyl chloride (6.8 g, 45.0 mmol) was added portionwise to a 0 °C solution of D-glucal (6.0 g, 41.0 mmol) and imidazole (6.1 g, 89.7 mmol) in anhydrous DMF (30 mL) under argon. The solution was allowed to come to room temperature slowly and then stirred overnight. The mixture was partitioned between ethyl acetate (250 mL) and water (250 mL), and the layers were separated. The aqueous layer was extracted with further ethyl acetate (2 \times 250 mL), and the combined organic extracts were dried (Na_2SO_4), filtered, and evaporated *in vacuo*. The residue was purified by flash chromatography (eluant 10–40% ethyl acetate:hexane) to afford 6.37 g (60% yield) of the title compound as a viscous clear oil: $[\alpha]_{\text{D}}^{20} + 2.4^\circ$ (c 0.5, CHCl_3); FTIR (film) 3386, 2930, 2857, 1651, 1472, 1389, 1254, 1205, 1105, 1052, 939, 836 cm^{-1} ; ^1H NMR (400 MHz, CDCl_3) δ 6.34 (dd, $J = 6.05, 1.65$ Hz, 1H, H-1), 4.75 (dd, $J = 6.05, 2.35$ Hz, 1H, H-2), 4.27 (s, 1H, H-3), 4.01 (dt, $J = 11.1, 1.75$ Hz, 1H, H-4), 3.91 (dt, $J = 11.1, 1.75$ Hz, 1H, H-5), 3.81 (d, $J = 3.6$ Hz, 2H, 2xH-6), 3.01 (s, 1H, OH), 2.36 (s, 1H, OH), 0.92 (s, 9H, *tert*-butyl), 0.12 (s, 6H, SiMe_2); ^{13}C NMR (75 MHz, CDCl_3) δ 144.1, 102.5, 77.2, 71.5, 69.4, 63.4, 25.8, 18.3.

(4-*O*-Benzoyl-6-deoxy-2,3-di-*O*-benzyl- α -L-galactopyranosyl)-(1 \rightarrow 3)-1,5-anhydro-6-*O*-(*tert*-butyldimethylsilyl)-2-deoxy-D-arabino-hex-1-enopyranose (43). 6-*O*-(*tert*-Butyldimethylsilyl)-D-glucal **44** (345 mg, 1.33 mmol) and fucosyl fluoride **13** (425 mg, 0.94 mmol) were placed in a dry flask and azeotroped three times from benzene. They were then diluted in 10 mL of dry ether and cannulated into a dry flask containing AgClO_4 (391 mg, 1.89 mmol), SnCl_2 (360 mg, 1.89 mmol), 2,6-di-*tert*-butylpyridine (0.43 mL, 1.89 mmol), and flame dried powdered 4 Å molecular sieves (1.4g) under an argon atmosphere. The mixture was refluxed for 48 h in the dark, after which time it was diluted with 20 mL of ether and filtered through Celite. The resulting solution was concentrated *in vacuo* and the residue subjected directly to flash chromatography (gradient elution, 6–12% ethyl acetate:hexanes) to afford 360 mg (55% yield) of the title compound as a clear gel: $[\alpha]_{\text{D}}^{20} - 120.0^\circ$ (c 0.25, CHCl_3); FTIR (film) 3446, 2929, 2857, 1724, 1650, 1454, 1361, 1270, 1096, 1055, 1026, 837 cm^{-1} ; ^1H NMR (400 MHz, CDCl_3) δ 8.06 (d, $J = 7.5$ Hz, 2H), 7.60 (t, $J = 6.9$ Hz, 1H), 7.47 (t, $J = 7.7$ Hz, 2H), 7.27 (m, 10H), 6.40 (d, $J = 6.2$ Hz, 1H, H-1 Glu), 5.67 (d, $J = 3.2$ Hz, 1H, H-4 Fuc), 5.01 (d, $J = 3.95$ Hz, 1H, H-1 Fuc), 4.85 (d, $J = 12.1$ Hz, 1H, OCH_2Ph), 4.80 (m, 2H), 4.66 (d, 12.1H, OCH_2Ph), 4.59 (d, $J = 11.3$ Hz, 1H, OCH_2Ph), 4.41 (q, $J = 6.4$ Hz, 1H, H-5 Fuc), 4.15 (d, $J = 6.9$ Hz, 1H), 4.11 (dd, $J = 10.25, 3.3$ Hz, 1H, H-4 Glu), 3.97 (s, 2H), 3.91 (d, $J = 9.8$ Hz, 1H), 3.76–3.86 (m, 2H), 1.20 (d, $J = 6.6$ Hz, 3H, CH_3), 0.92 (s, 9H, *tert*-butyl), 0.10 (s, 6H, SiMe_2); ^{13}C NMR (75 MHz, CDCl_3) δ 166.2, 145.2, 138.5, 138.2, 133.0, 129.8, 128.3, 128.2, 127.9, 127.8, 127.5, 127.3, 100.0, 97.8, 79.6, 78.0, 76.2, 75.1, 73.4, 71.9, 71.4, 68.1, 66.0, 82.6,

25.9, 18.4, 16.2; HRMS (FAB) calcd for $\text{C}_{39}\text{H}_{50}\text{O}_9\text{SiNa}$ 713.3121 ($\text{M} + \text{Na}^+$), found 713.3135.

1,5-Anhydro-6-*O*-(*tert*-butyldimethylsilyl)-2-deoxy-D-lyxo-hex-1-enopyranose (46). *tert*-Butyldimethylsilyl chloride (4.8 g, 31.8 mmol) was added portionwise to a 0 °C solution of D-galactal (4.2 g, 28.8 mmol) and imidazole (4.3 g, 63.2 mmol) in anhydrous DMF (20 mL) under argon. The mixture was allowed to come to room temperature slowly and then stirred overnight. The mixture was partitioned between ethyl acetate (250 mL) and water (250 mL), and the layers were separated. The aqueous layer was extracted with further ethyl acetate (2 \times 250 mL), and the combined organic extracts were dried (Na_2SO_4), filtered, and evaporated *in vacuo*. The residue was purified by flash chromatography (eluant, 15–30% ethyl acetate:hexane) to afford 5.25 g (70% yield) of the title compound as a viscous pale yellow oil: $[\alpha]_{\text{D}}^{20} + 12.4^\circ$ (c 0.5, CHCl_3); FTIR (film) 3417, 2929, 2857, 1651, 1641, 1463, 1403, 1361, 1254, 1143, 1031, 839 cm^{-1} ; ^1H NMR (400 MHz, CDCl_3) δ 6.38 (dd, $J = 6.25, 1.4$ Hz, 1H, H-1), 4.73 (dt, $J = 6.25, 2.0$ Hz, 1H, H-2), 4.32 (dt, $J = 10.25, 2.30$ Hz, 1H, H-3), 4.11 (tt, $J = 4.9, 1.6$ Hz, 1H, H-4), 3.98 (dd, $J = 10.9, 4.95$ Hz, 1H, H-6), 3.93 (dd, $J = 10.9, 3.65$ Hz, 1H, H-6), 3.89 (t, $J = 3.5$ Hz, 1H, H-5), 3.21 (d, $J = 5.0$ Hz, 1H, OH), 2.72 (d, $J = 10.35$ Hz, 1H, OH), 0.92 (s, 9H, *tert*-butyl), 0.12 (s, 6H, SiMe_2); ^{13}C NMR (75 MHz, CDCl_3) δ 144.5, 103.0, 75.9, 65.9, 64.2, 63.2, 25.8, 18.2; HRMS (CI) calcd for $\text{C}_{12}\text{H}_{28}\text{NO}_4\text{Si}$ 278.1788 ($\text{M} + \text{NH}_4^+$), found 278.1797.

1,5-Anhydro-6-*O*-(*tert*-butyldimethylsilyl)-3,4-*O*-carbonyl-2-deoxy-D-lyxo-hex-1-enopyranose (41). Dicarboxylimidazole (2.4 g, 14.8 mmol) was added to a solution of compound **46** (4.3 g, 14.2 mmol) in anhydrous THF (40 mL) under argon. Three crystals of imidazole were added, and the mixture was stirred at room temperature for 30 min. Further dicarbonylimidazole (1.2 g, 7.4 mmol) was added, and the mixture was stirred for a further 90 min. The solvent was removed *in vacuo* and the residue partitioned between methylene chloride (200 mL) and water (100 mL). The organic layer was separated, washed with brine (100 mL), dried (Na_2SO_4), filtered, and evaporated *in vacuo*. The residue was subjected to flash chromatography (eluant, 15% ethyl acetate:hexane) to yield the title compound (3.80 g, 82%) as a clear syrup: $[\alpha]_{\text{D}}^{20} - 68.2^\circ$ (c 0.5, CHCl_3); FTIR (film) 2930, 2858, 1790, 1651, 1472, 1404, 1368, 1318, 1248, 1163, 1112, 1068, 846 cm^{-1} ; ^1H NMR (400 MHz, CDCl_3) δ 6.66 (d, $J = 6.5$ Hz, 1H, H-1), 5.19 (dd, $J = 7.6, 3.15$ Hz, 1H, H-2), 4.96 (d, $J = 7.0$ Hz, 1H, H-4), 4.93 (dt, $J = 1.3, 3.15$ Hz, 3H, H-3), 3.90 (m, 3H, 2 \times H-6, H-5), 0.90 (s, 9H, *tert*-butyl), 0.10 (s, 6H, SiMe_2); ^{13}C NMR (75 MHz, CDCl_3) δ 154.1, 149.1, 98.1, 74.0, 72.8, 68.9, 61.1, 25.7, 18.1; HRMS (CI) calcd for $\text{C}_{13}\text{H}_{26}\text{NO}_5\text{Si}$ 304.1580 ($\text{M} + \text{NH}_4^+$), found 304.1583.

[(4-*O*-Benzoyl-6-deoxy-2,3-di-*O*-benzyl- α -L-galactopyranosyl)-(1 \rightarrow 3)-(6-*O*-(*tert*-butyldimethylsilyl)-3,4-*O*-carbonyl- β -D-galactopyranosyl)-(1 \rightarrow 4)]-1,5-anhydro-6-*O*-(*tert*-butyldimethylsilyl)-2-deoxy-D-arabino-hex-1-enopyranose (47). Dimethyldioxirane (30 mL of a ca. 0.05 M solution in acetone, 15.0 mmol) was added dropwise to a 0 °C solution of glycol **41** (220 mg, 7.43 mmol) in methylene chloride (5 mL). The mixture was stirred at 0 °C for 1 h, after which time TLC analysis indicated the complete consumption of **41**. The mixture was evaporated *in vacuo*, then azeotroped with benzene (5 mL), leaving presumed **42** as a residue. Disaccharide **43** (256 mg, 0.37 mmol) was added, and the mixture was azeotroped with further benzene (2 \times 5 mL) and dried *in vacuo* before being taken up in anhydrous THF (1.5 mL) and chilled to -78 °C under argon. A solution of zinc bromide (820 μL of a 1 M solution in THF, 0.82 mmol) was added dropwise and the mixture allowed to come slowly to room temperature overnight. The mixture was then poured into ice-cold NaHCO_3 solution (10 mL) and extracted into ethyl acetate (3 \times 20 mL). The combined organic extracts were dried (Na_2SO_4), filtered, and evaporated, and the residue was purified by flash chromatography (gradient elution, 10–25% ethyl acetate:hexanes) to yield (in order of elution) recovered **43** (43 mg, 17%) and the title compound (299 mg, 81% yield) as a white solid: $[\alpha]_{\text{D}}^{20} - 82.4^\circ$ (c 0.5, CHCl_3); FTIR (neat) 3447, 2954, 2884, 2857, 1723, 1648, 1454, 1362, 1270, 1167, 1058, 838 cm^{-1} ; ^1H NMR (400 MHz, CDCl_3) δ 8.05 (d, $J = 7.0$ Hz, 2H), 7.59 (t, $J = 7.4$ Hz, 1H), 7.47 (t, $J = 7.3$ Hz, 2H), 7.30 (s, 10H), 6.40 (d, $J = 7.3$ Hz, 1H, H-1 Glu), 5.63 (d, $J = 2.4$ Hz, 1H, H-4 Fuc), 5.03 (d, $J = 3.8$ Hz, 1H, H-1 Fuc), 4.86 (d, $J = 11.4$ Hz, 1H, OCH_2Ph), 4.85 (dd, $J = 5.95, 2.6$ Hz, 1H, H-2 Glu), 4.81 (d, $J = 7.7$ Hz, 1H, H-1 Gal), 4.80 (d, $J = 11.7$

H_z, 1H, OCH₂Ph), 4.65 (d, *J* = 11.7 Hz, 1H, OCH₂Ph), 4.61 (dd, *J* = 6.9, 1.8 Hz, 1H), 4.54 (d, *J* = 11.0 Hz, 1H, OCH₂Ph), 4.49 (m, 2H), 4.24 (m, 2H), 4.10 (dd, *J* = 7.85, 2.8 Hz, 1H), 4.07 (dd, *J* = 6.0, 3.1 Hz, 1H), 3.82–3.95 (m, 5H), 3.75 (dt, *J* = 1.95, 6.2 Hz, 1H), 3.60 (dt, *J* = 2.6, 7.1 Hz, 1H), 3.51 (d, *J* = 2.55 Hz, 1H), 1.16 (d, *J* = 6.6 Hz, 3H, CH₃), 0.93 (s, 9H, *tert*-butyl), 0.89 (s, 9H, *tert*-butyl), 0.12 (s, 6H, SiMe₂), 0.08 (s, 6H, SiMe₂); ¹³C NMR (75 MHz, CDCl₃) δ 166.1, 153.8, 145.4, 138.3, 138.2, 133.0, 130.1, 129.8, 128.3, 128.2, 127.7, 127.4, 100.6, 99.3, 95.2, 78.8, 76.9, 76.6, 75.1, 74.4, 73.9, 73.3, 73.2, 73.1, 72.5, 71.7, 71.3, 65.4, 61.5, 26.0, 25.8, 18.4, 18.2, 16.3.

[(6-Deoxy-α-L-galactopyranosyl)-(1→3)]-(β-D-galactopyranosyl)-(1→4)]-1,5-anhydro-2-deoxy-D-arabino-hex-1-enopyranose (48). Trisaccharide 47 (48 mg, 47.9 μmol) was dissolved in THF (2.5 mL) and treated sequentially with acetic acid (105 μL of a 1 M solution in THF, 105 μmol) and tetrabutylammonium fluoride (105 μL of a 1 M solution in THF, 105 μmol). The mixture was stirred at room temperature for 12 h, after which time further aliquots of acetic acid and tetrabutylammonium fluoride were added (50 μL of each, 50 μmol) and the mixture stirred for a further 4 h. The solvent was removed *in vacuo* and the residue partitioned between water and ethyl acetate (10 mL each). The organic layer was separated, washed with NaHCO₃ solution (5 mL), dried (Na₂SO₄), filtered, evaporated, and purified by passage through a short silica column (eluant, ethyl acetate). The solvent was removed *in vacuo* to yield the desilylated trisaccharide (26 mg) which was used directly in the next step.

A solution of the desilylated material in THF (100 μL) was added to a -78 °C solution of sodium (small piece) in ammonia, and the blue solution was allowed to reflux under a cold trap for 30 min. The mixture was then recooled to -78 °C and quenched *carefully* with methanol (1 mL). The mixture was allowed to warm to room temperature, the ammonia evaporated in a stream of argon, and further methanol (4 mL) added. The resulting solution was allowed to stir overnight. The solution was then cooled to 0 °C and carefully acidified to pH 8 with prewashed Dowex 50×8–400 resin. The mixture was filtered, evaporated, azeotroped with toluene (2 × 5 mL), and dried *in vacuo*. The residue was taken up in pyridine (3 mL) and treated with acetic anhydride (3 mL) and (dimethylamino)pyridine (one crystal), allowing to stir overnight. The mixture was then partitioned between water (5 mL) and ethyl acetate (20 mL), and the organic layer was separated, washed with NaHCO₃ solution (3 × 10 mL), water (10 mL), and CuSO₄ solution (3 × 10 mL), and dried (Na₂SO₄). Following removal of the solvent *in vacuo*, the residue was purified by flash chromatography (eluant, 60% ethyl acetate:hexanes) to give the peracetylated trisaccharide (17 mg) as a white foam: ¹H NMR (400 MHz, CDCl₃) δ 6.40 (d, *J* = 6.2 Hz, 1H), 5.45 (d, *J* = 3.4 Hz, 1H), 5.27 (dd, *J* = 11.0, 2.45 Hz, 1H), 5.26 (d, *J* = 3.65 Hz, 1H), 5.17 (m, 2H), 5.04 (dd, *J* = 10.0, 3.0 Hz, 1H), 4.78 (dd, *J* = 5.9, 2.6 Hz, 1H), 4.61 (m, 2H), 4.51 (d, *J* = 11.0 Hz, 1H), 4.40 (dd, *J* = 11.15, 6.1 Hz, 1H), 4.32 (s, 1H), 4.27–4.08 (m, 4H), 3.95 (d, *J* = 6.95 Hz, 1H), 2.21 (s, 3H), 2.20 (s, 3H), 2.17 (s, 3H), 2.10 (s, 6H), 2.09 (s, 3H), 2.02 (s, 3H), 2.00 (s, 3H), 1.23 (d, *J* = 6.2 Hz, 3H).

The peracetylated trisaccharide was dissolved in methanol (3 mL), treated with sodium methoxide (2 drops of a 10% solution in methanol), and allowed to stir overnight. The mixture was evaporated *in vacuo* and purified by passage through a short silica column (eluant, methanol)

followed by filtration through a reverse-phase silica plug (eluant, methanol). The solvent was removed *in vacuo* to yield the title compound (6.4 mg, 29% over four steps) as a white film: [α]_D²⁰ -136.4° (*c* 0.25, CH₃OH); FTIR (neat) 3406, 2917, 2850, 1650, 1564, 1414, 1238, 1165, 1078, 1020, 971 cm⁻¹; ¹H NMR (400 MHz, CD₃OD) δ 6.40 (d, *J* = 6.1 Hz, 1H), 4.85 (d, *J* = 2.5 Hz, 1H), 4.60 (d, *J* = 6.6 Hz, 1H), 4.89 (d, *J* = 6.75 Hz, 1H), 4.37 (d, *J* = 5.0 Hz, 1H), 4.13 (dd, *J* = 11.8, 3.65 Hz, 1H), 3.96 (dd, *J* = 11.8, 3.65 Hz, 1H), 3.91–3.84 (m, 3H), 3.80 (d, *J* = 2.65 Hz, 1H), 3.78–3.65 (m, 5H), 3.48 (m, 2H), 1.17 (d, *J* = 6.6 Hz, 3H); ¹³C NMR (75 MHz, CD₃OD) δ 145.8, 104.1, 100.5, 97.2, 79.8, 76.8, 74.9, 73.7, 73.1, 73.1, 71.9, 71.5, 70.1, 70.0, 67.6, 62.8, 60.9, 49.8, 16.5.

[(4-*O*-Benzoyl-6-deoxy-2,3-di-*O*-benzyl-α-L-galactopyranosyl)-(1→3)]-[(6-*O*-(*tert*-butyldimethylsilyl)-β-D-galactopyranosyl)-(1→4)]-1,5-anhydro-6-*O*-(*tert*-butyldimethylsilyl)-2-deoxy-D-arabino-hex-1-enopyranose (49). Sodium methoxide (10 μL of a 10% solution in methanol) was added dropwise to a solution of trisaccharide 47 (154 mg, 155 μmol) in methanol (5 mL) under argon and the mixture allowed to stir overnight. The solvent was then removed *in vacuo* and the residue purified by flash chromatography (eluant, 50% ethyl acetate:hexanes) to afford the title compound (134 mg, 89% yield) as a white solid: [α]_D²⁰ -62.0° (*c* 0.5, CHCl₃); FTIR (neat) 3432, 2928, 2856, 1722, 1647, 1458, 1388, 1361, 1271, 1101, 1071, 838 cm⁻¹; ¹H NMR (400 MHz, CDCl₃) δ 8.05 (d, *J* = 7.3 Hz, 2H), 7.60 (t, *J* = 7.4 Hz, 1H), 7.48 (t, *J* = 7.8 Hz, 2H), 7.33–7.12 (m, 10H), 6.41 (d, *J* = 6.0 Hz, 1H), 5.65 (d, *J* = 2.7 Hz, 1H), 4.94 (d, *J* = 5.65 Hz, 1H), 4.88 (d, *J* = 9.4 Hz, 1H), 4.85 (d, *J* = 10.7 Hz, 1H), 4.81–4.67 (m, 4H), 4.60 (d, *J* = 10.75 Hz, 1H), 4.43 (d, *J* = 7.0 Hz, 1H), 4.32 (t, *J* = 8.1 Hz, 1H), 4.15–4.08 (m, 3H), 3.96–3.81 (m, 5H), 3.61 (t, *J* = 8.0 Hz, 1H), 3.51 (d, *J* = 7.0 Hz, 1H), 3.40 (dd, *J* = 8.75, 5.1 Hz, 1H), 3.15 (s, 1H), 2.83 (s, 1H), 2.63 (s, 1H), 1.16 (d, *J* = 6.55 Hz, 3H), 0.94 (s, 9H), 0.89 (s, 9H), 0.11 (s, 6H), 0.08 (s, 6H); ¹³C NMR (75 MHz, CDCl₃) δ 166.3, 145.1, 138.5, 138.3, 132.9, 129.9, 129.8, 128.3, 128.2, 128.1, 127.7, 127.4, 127.3, 101.7, 99.2, 95.6, 78.1, 78.0, 74.5, 73.6, 72.8, 72.7, 72.2, 72.0, 71.8, 71.7, 67.4, 65.1, 61.3, 61.0, 26.0, 25.8, 18.4, 18.2, 16.3.

Acknowledgment. This work was supported by the National Institutes of Health, Grant No. HL-25848 (S.J.D.). J.G. is grateful to the National Institutes of Health for a Postdoctoral Fellowship, 1990–1992. J.M.P. is grateful to Yale University for a Kent Graduate Fellowship. F.E.M. is grateful to the ACS for a Postdoctoral Fellowship, 1990–1992. K.K. is grateful for support from Japan Tobacco, Inc., during leave, 1991–1992. D.A.G. is grateful to Yale University for a Dox Graduate Fellowship. T.O. is grateful to Ibaraki University for support during leave, 1991–1992. S.P.M. is grateful to the Engineering and Physical Sciences Research Council (U.K.) for a NATO postdoctoral fellowship. NMR spectra were obtained through the auspices of the Northeast Regional NSF/NMR Facility at Yale University, which was supported by NSF/Chemistry Division Grant CHE 7916210.

JA9416403